

This copy is a reprint which includes current pages from Changes 1 and 2.

TM 9-2990-206-34&P

TECHNICAL MANUAL

DIRECT SUPPORT AND GENERAL SUPPORT MAINTENANCE MANUAL [INCLUDING REPAIR PARTS AND SPECIAL TOOLS LISTS]

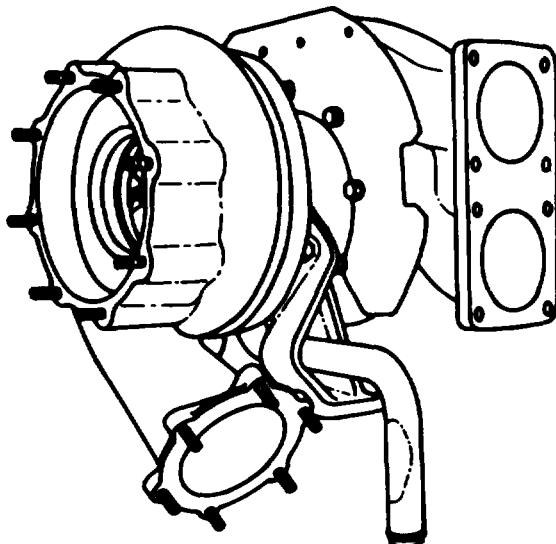

TURBOSUPERCHARGER AIRESEARCH MODEL T18C01

TROUBLESHOOTING
PAGE 2-1

DISASSEMBLY
PAGE 3-1

CLEANING
AND REPAIR
PAGE 3-10.2

ASSEMBLY
PAGE 3-18

REPAIR
PARTS LIST
PAGE B-6

TEST AND
PRESERVATION
PAGE 4-1

NSN 2950-01-048-8870 [11669107-1],
AND 2950-01-167-1699 [466392-1]

HEADQUARTERS, DEPARTMENT OF THE ARMY
25 JANUARY 1980

TA293540

WARNING

Particles blown by compressed air are hazardous. Make certain the air stream is not directed at any person. Protect eyes and face with appropriate shields.

END ITEM APPLICATION

■ Turbosuperchargers 11669107-1 and 466392-1 used on Engines AVDS-1790-2C, AVDS-1790-2CA, AVDS-1790-2D, AVDS-1790-2DA, and AVDS-1790-2DR

<u>Vehi cl es</u>	<u>TM No.</u>	<u>Series</u>
Tank, Combat, Full Tracked: 105-MM Gun, M48A5	9-2350-258	
Tank, Combat, Full Tracked: 105-MM Gun, M60 and M60A1	9-2350-215	
Tank, Combat, Full Tracked: 105-MM Gun, M60A1 (RI SE)	9-2350-257	
Tank, Combat, Full Tracked: 105-MM Gun, M60A3	9-2350-253	
Armored Vehi cl e Launched Bridge: M48A2 AVLB	5-5420-200	
Armored Vehi cl e Launched Bridge: M60A1 AVLB	5-5420-202	
Armored Vehi cl e Launched Bridge: M48A5 AVLB	5-5420-226	
Vehi cl e, Combat Engi neer, Full Tracked: M728	9-2350-222	
Recovery Vehi cl e, Full Tracked: Medi um, M88A1	9-2350-256	

Change
No. 2

C2
HEADQUARTERS
DEPARTMENT OF THE ARMY
Washington, DC, 8 February 1985

Direct Support and General Support Maintenance Manual
(Including Repair Parts and Special Tools List)

for

TURBOSUPERCHARGER

AI RESEARCH MODEL T18C01
NSN 2950-01-048-8870 (11669107-1)
AND 2950-01-167-1699 (466392-1)

TM 9-2990-206-34&P, 25 January 1980, is changed as follows:

1. Remove old pages and insert new pages as indicated below.
2. New or changed material is indicated by a vertical bar in the margin of the page.

Remove pages

i and ii

Insert pages

i and ii

File this change sheet in front of the publication for reference purposes.

TM 9-2990-206-34&P

By Order of the Secretary of the Army

Official:

JOHN A. WICKHAM, JR.
General United States Army
Chief of staff

DONALD J. DELANDRO
Brigadier General United States Army
The Adjutant General

Distribution

To be distributed in accordance with DA Form 12-37, Direct and General Support Maintenance requirements for Recovery Vehicle, Medium, M88A1; Tanks, Combat, Full Tracked, 105mm, M60; Miscellaneous Combat Vehicle, Combat Engineer, Full Track, M728; Tank Bridge Launcher, At' LB; Tank, Combat, Full Tracked, 105mm, M60A1 (RISE); Tank Combat, Full Tracked, 105mm, M48A5 and Tank, Combat, W/Turret M60A3.

Change
No. 1

c 1
HEADQUARTERS
DEPARTMENT OF THE ARMY
Washington, DC, 27 April 1984

**Direct Support and General Support Maintenance Manual
(Including Repair Parts and Special Tools List)**

for

TURBOSUPERCHARGER

**AIRESEARCH MODEL T18C01
NSN 2950-01-048-8870 (11669107-1)
AND 2950-01-167-1699 (466392-1)**

TM 9-2990-206-34&P, 25 January 1980, is changed as follows:

1. Title is changed as shown above.
2. Remove and insert pages as indicated below.

Remove pages	Insert pages
Warning page	Warning page
i thru iv	i thru iv
1-1 and 1-2	1-1 and 1-2
None	1-2. 1 (1-2. 2 blank)
1-3 and 1-4	1-3 and 1-4
3-3 and 3-4	3-3 and 3-4
3-9 and 3-10	3-9 and 3-10
None	3-10. 1 and 3-10. 2
3-15 and 3-16	3-15 and 3-16
None	3-16. 1 (3-16. 2 blank)
3-23 thru 3-26	3-23 thru 3-26
None	(3-26. 1 blank) 3-26. 2
3-27 (3-28 blank)	3-27 thru 3-30
B-1 and B-2	B-1 and B-2
B-7 and B-8	B-7 and B-8
None	B-8. 1 thru B-8. 4
B-9 thru B-11 (B-12 blank)	B-9 thru B-12
Index 1 through Index 3	Index 1 through Index 3
Cover	Cover

3. New or changed text material is indicated by a vertical bar in the margin. An illustration change is indicated by a miniature pointing hand.
4. Retain this sheet in front of manual for reference purposes.

TM9-2990-206-34&P

By Order of the Secretary of the Army:

JOHN A. WICKHAM, JR.
General, United States Army
Chief of Staff

Official:

ROBERT M. JOYCE
Major General, United States Army
The Adjutant General

Distribution:

To be distributed in accordance with DA Form 12-37, Direct and General Support Maintenance requirements for Recovery~Vehicle, Medium, M88A1; Tanks, Combat, Full Tracked, 105MM, M60, M60A1; Combat Engineer, Full Track, M728; Tank, Bridge Launcher, AVLB; Tank, Combat, Full Tracked: 105MM Gun, M60A1 (RISE); Tank, Combat, Full Tracked, 105MM Gun, M48A5, and M60A3 Tank Turret.

**HEADQUARTERS
DEPARTMENT OF THE ARMY
Washington, DC, 25 January 1980**

Direct and General Support Maintenance Manual
(Including Repair Parts, And Special Tools List)

for

TURBOSUPERCHARGER
AI RESEARCH MODEL T18C01

NSN 2950-01-048-8870 (11669107-1) and
2950-01-167-1699 (466392-1)

Current as of 15 December 1983

REPORTING ERRORS AND RECOMMENDING IMPROVEMENTS

You can help improve this manual. If you find any mistakes or if you know of a way to improve the procedures, please let us know. Mail your letter, DA Form 2028 (Recommended Changes to Publications and Blank Forms), or DA Form 2028-2 located in the back of this manual direct to: Commander, US Army Tank-Automotive Command, Warren, MI 48090, ATTN: DRSTA-MB. A reply will be furnished to you.

TABLE OF CONTENTS

	Page
HOW TO USE THIS MANUAL.....	iii
CHAPTER 1 INTRODUCTION.....	1-1
Section I General Information.....	1-1
Section II Equipment Description and Data.....	1-2
CHAPTER 2 MAINTENANCE INSTRUCTIONS.....	2-1
Section I Troubleshooting.....	2-1
Section II General Maintenance.....	2-5
CHAPTER 3 MAINTENANCE OPERATIONS.....	3-1
Section I General.....	3-1
Section II Disassembly.....	3-1
Section III Cleaning, inspection, and Repair.....	3-10. 2
Section IV Assembly.....	3-18
CHAPTER 4 TEST AND PRESERVATION.....	4-1

TM 9-2990-206-34&P

APPENDIX A. REFERENCES A-1

 Section I General Information A-1

 Section 11 Technical and Reference Manuals A-1

APPENDIX B. REPAIR PARTS AND SPECIAL TOOLS LISTS B-1

 Section I Introduction B-1

 Section II Repair Parts List B-6

 Section III Special Tools List B-10

 Section IV National Stock Number and Part Number Index B-11

APPENDIX C. EXPENDABLE SUPPLIES AND MATERIALS LIST C-1

 ALPHABETICAL INDEX INDEX

HOW TO USE THIS MANUAL

You must familiarize yourself with the entire maintenance procedures before beginning the maintenance task.

This manual describes the procedures to be followed to repair the Ai Research Model T18C01 turbosupercharger. It is divided into four chapters and three appendixes.

Chapter 1 includes general introductory information and description of the turbosuperchargers. There are two turbosupercharger configurations, standard and "clean air", covered by this manual. These two configurations are basically similar, and all descriptive information in Chapter 1 applies to both. The nomenclature cross-reference list (page 1-1) will help you find repair parts in the Repair Parts and Special Tools Lists by official nomenclature.

Chapter 2 includes troubleshooting procedures, and the tools required to repair the turbosupercharger.

Chapter 3 includes instructions for disassembly, cleaning, inspection, repair, and assembly of the turbosupercharger. You will note that throughout the disassembly portion of this chapter, you are instructed to "remove and discard" certain items. These discarded items are furnished in the turbosupercharger parts kit, and all parts in the kit must be used during assembly.

Chapter 4 includes test and preservation information.

The three Appendixes are:

- Appendix A, References
- Appendix B, Repair Parts and Special Tools Lists
- Appendix C, Expendable Supplies and Materials

All referencing within this publication is by page number or to other technical manuals.

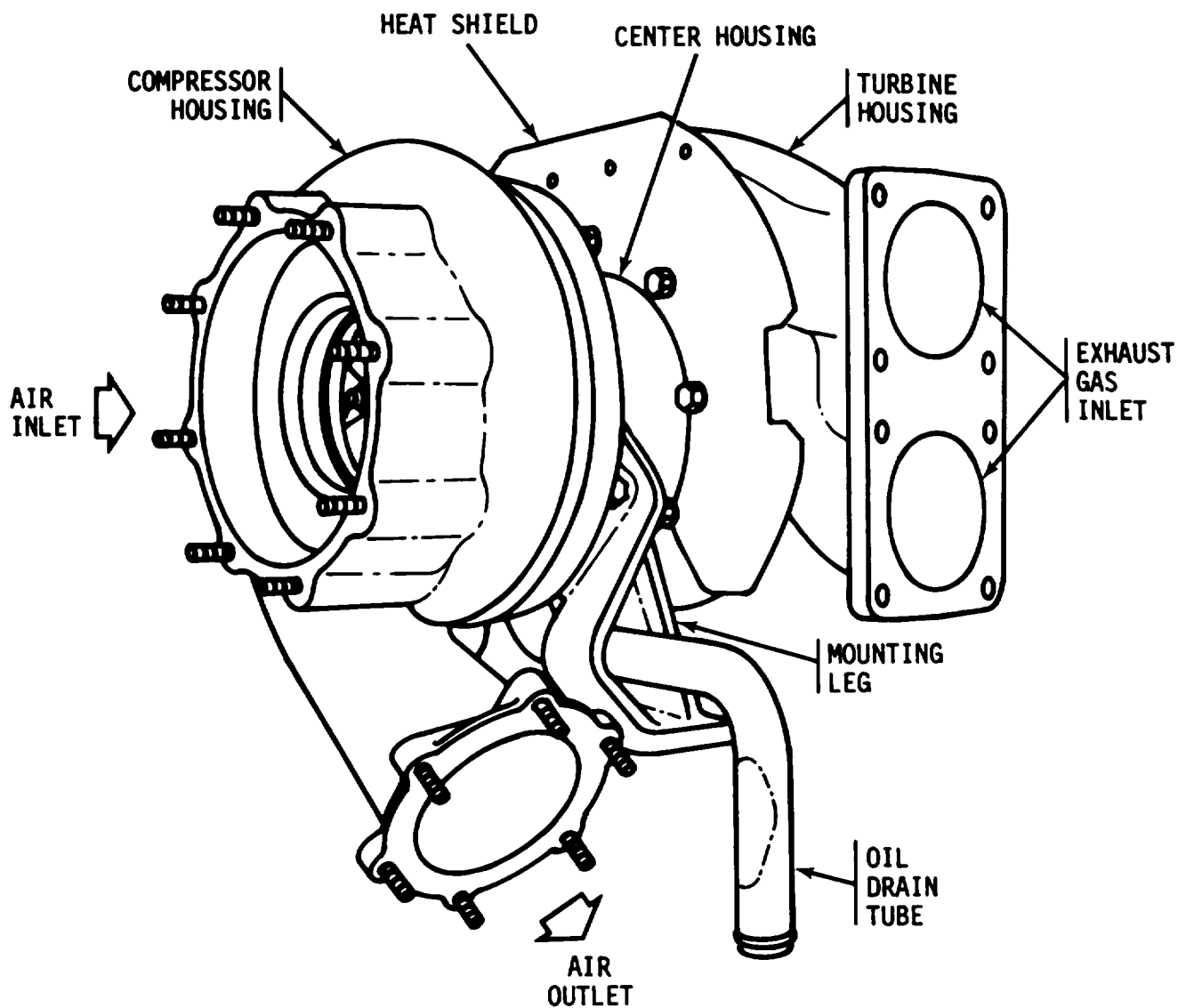

Turbosupercharger - typical
left hand mounting.

CHAPTER 1

INTRODUCTION

Section 1. GENERAL INFORMATION

1-1. SCOPE.

a. Type of Manual. This technical manual contains instructions for Direct and General Support Maintenance of the Ai Research Industrial Division Model T18C01 turbosupercharger.

b. Identification. The two configurations of Model T18C01 turbosuperchargers covered by this manual are part numbers 466392-1 ("clean air") and 11669107-1 (standard). These two configurations can be either right or left hand mounted on various AVDS-1790 series engines used in army vehicles.

c. Purpose of Equipment. Turbo-superchargers are exhaust gas driven centrifugal compressors. Their purpose is to increase the amount of air delivered to engine cylinders above that available through unassisted air intake.

1-2. MAINTENANCE FORMS, RECORDS, AND REPORTS.

Department of the Army forms and records used for equipment maintenance will be those prescribed by TM 38-750, The Army Maintenance Management System (TAMMS).

1-3. NOMENCLATURE CROSS-REFERENCE LIST.

This listing includes nomenclature cross-references used in this manual.

<u>Common Name</u>	<u>Official Nomenclature</u>
Backplate	Back Plate, Supercharger
Bolt	Bolt, Machine
Center Housing	Housing Assembly, Center
Clamp	Coupling, Clamp, Grooved
Compressor Wheel	Impeller, Turbosupercharger
Compressor Wheel Nut	Nut, Impeller
Heat Shield	Shield, Turbosupercharger
Insert	Insert, Screw Thread
Lockwasher	Washer, Lock
Nut	Nut, Self-Locking, Castellated, Hexagon
Nut	Nut, Self-Locking, Hexagon
Oil Drain Tube	Tube Assembly, Metal
"O" Ring	Packings, Preformed
"O" Ring	Seal, Ring
Seal Ring	Seal, Ring, Metal
Shroud	Wheel, Shroud
Spacer Ring	Ring, Turbocharger
Stud	Stud, Plain
Thrust Ring	Ring, Thrust, Turbocharger
Thrust Washer	Washer, Bearing, Thrust
Turbine Wheel	Turbine Wheel Assembly

1-4. REPORTING EQUIPMENT IMPROVEMENT RECOMMENDATIONS (EIR).

EIR'S can and must be submitted by anyone who is aware of an unsatisfactory condition with the equipment design or use. It is not necessary to show a new design or list a better way to perform a pro-

cedure, just simply tell why the design is unfavorable or why a procedure is difficult. EIR's may be submitted on SF 368 (Quality Deficiency Report). Mail directly to Commander, U. S. Army Tank-Automotive Materiel Readiness Command, Warren, MI 48090, ATTN: DRSTA-MP. A reply will be furnished to you.

Section II. EQUIPMENT DESCRIPTION AND DATA

1-5. DESCRIPTION.

a. General. Engines equipped with turbosuperchargers deliver more power per pound of fuel than unturbosupercharged engines. Turbosuperchargers make use of the heat energy lost through engine exhaust gases. Exhaust gases from the engine drive the turbine wheel assembly which in turn drives the turbocharger impeller (compressor wheel).

b. Operation. The exhaust gases from the engine enter the turbine housing through the exhaust connection on the turbine housing. The gases flow around the housing and radially inward. The exhaust gas pressure and the heat energy extracted from the gas causes the turbine wheel to rotate. The exhaust gases then exit through the exhaust outlet of the turbine housing and vehicle exhaust system. Rotation of the turbine wheel causes the compressor wheel to rotate since they are mounted on a common shaft.

Air from the vehicle air filter enters at the center of the compressor wheel and flows radially outward through the compressor housing. The air increases

in pressure and leaves through an outlet on the outside of the compressor housing, and enters the engine induction system.

A center housing supports the turbine wheel, shaft, and compressor wheel. The turbine wheel shaft is supported by sleeve bearings. End play is controlled by a turbocharger thrust ring, thrust bearing, and thrust washers.

c. Lubrication. The turbosupercharger is pressure lubricated from the engine lubricating system through an external hose connected to the engine oil filter. The two turbine wheel shaft sleeve bearings have holes to direct oil, to the bearing bores and shaft journals. Oil passages in the center housing connect the oil inlet port with grooves machined in the bearing bores, which align with holes in the bearings. Oil leaves the center housing, via bearing clearances, through the oil drain tube to the engine oil pan. Two turbocharger rings (spacer rings) prevent oil from entering the compressor housing, and one metal ring seal (seal ring) prevents oil from entering the turbine housing.

d. Difference Between Models.

Turbosupercharger part number 466392-1 is designed for use on "clean air" engine models AVDS-1790-2CA and AVDS-1790-2DA. The "clean air" turbosupercharger has a dust detector cover assembly incorporated into the compressor housing. Turbosupercharger part number 11669107-1 is used on all other AVDS-1790 engine models and does not have a dust detector cover assembly. In all other respects, these two configurations are identical. Unless otherwise specified, the DS/GS maintenance and repair instructions in this manual pertain to both; however, only the standard turbosupercharger will be used to illustrate the procedures.

NOTE

For a complete description of the Dust Detector System for "clean air" engine models AVDS-1790-2CA and AVDS-1790-2DA, refer to TM 9-2815-220-34.

e. Difference Between Right and Left Hand Mounting. Both configurations of the turbosupercharger discussed in this manual can be either right or left hand mounted by indexing the turbine housing and compressor housing according to the mounting location and engine model. Also the position of the oil drain tube is reversed for right or left hand use. For engine model AVDS-1790-2DR the turbosupercharger heat shields are removed and discarded before the turbosuperchargers are mounted.

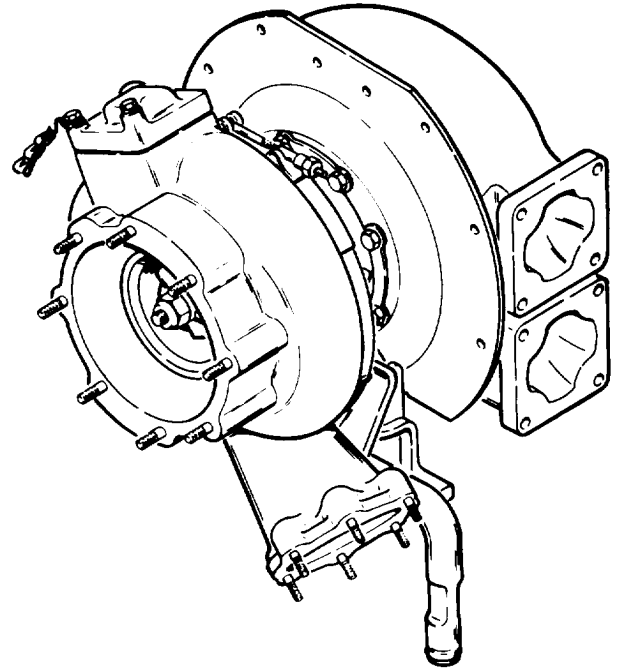

"Clean air" turbosupercharger.

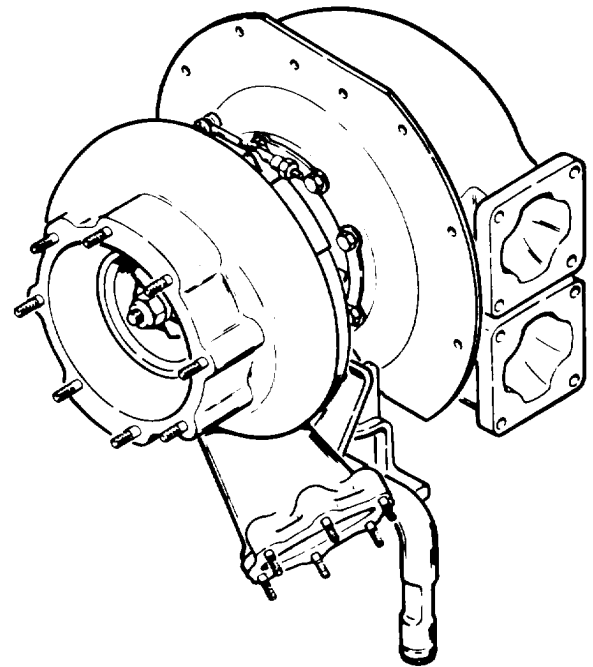

Standard turbosupercharger.

1-6. DELETED.

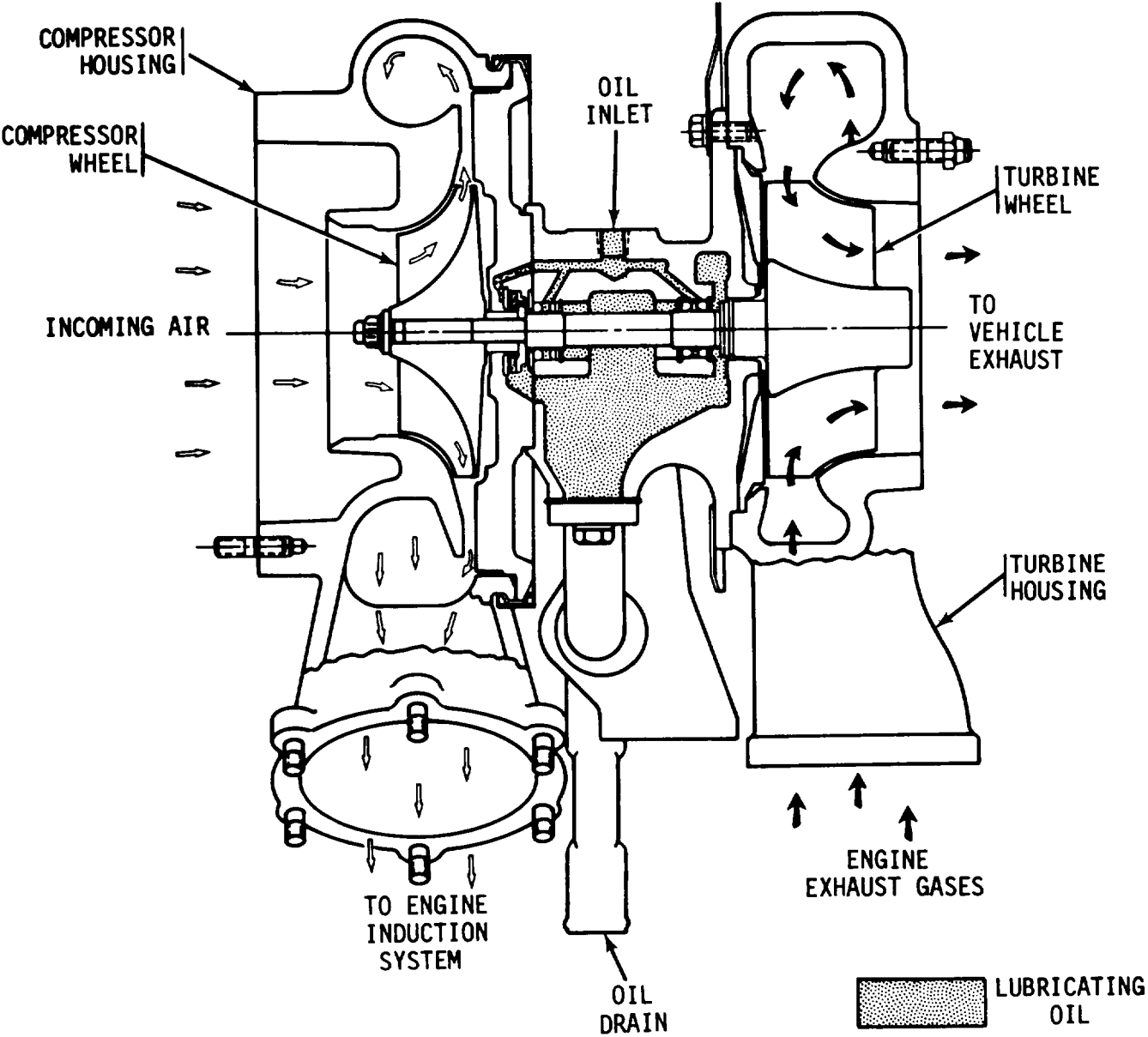

Air flow and lubrication system.

TA293545

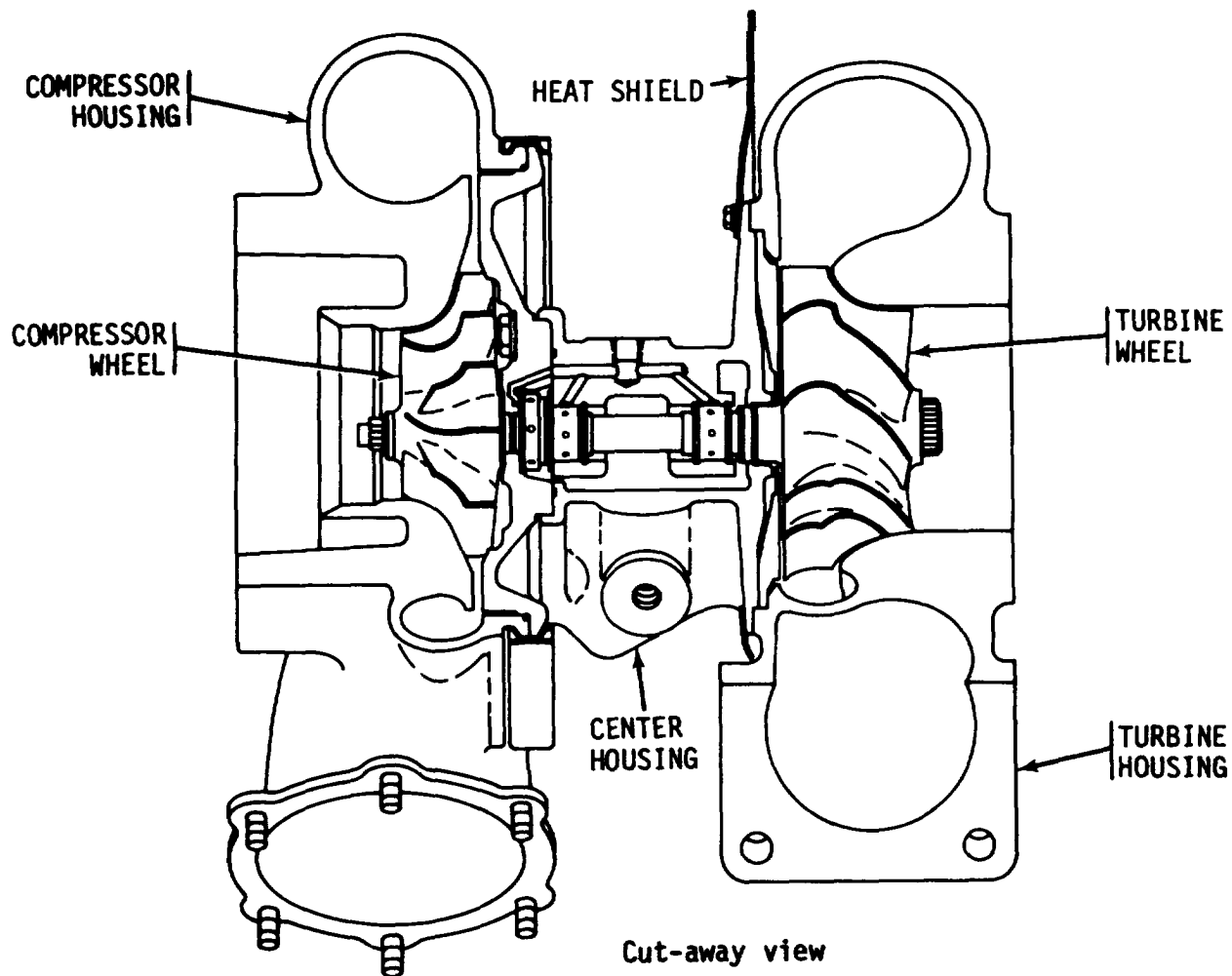

1-7 EQUIPMENT DATA.

a. General.

ManufacturerAiResearch Industrial Division
 Model T18C01
 Mounting Universal

b. Specifications.

Maximum revolutions per minute..... 65,000
 Diameter of compressor air inlet opening 6.50 in. (165.1 mm)
 Diameter of compressor air outlet opening3.50 in. (88.9mm)
 Diameter of each turbine exhaust inlet opening.3.00 in. (76.2mm)
 Diameter of turbine exhaust outlet opening4.25 in. (107.9 mm)
 Oil inlet pressure to center housing 40 to 70 psi (276 to 483 kPa)
 Oil outlet pressure from center housingcrankcase pressure

1-8. IDENTIFICATION PLATE.

The turbosupercharger identification plate is located on the backplate.

TA097804

CHAPTER 2

MAINTENANCE INSTRUCTIONS

Section 1. TROUBLESHOOTING

2-1. GENERAL.

a. Purpose. These troubleshooting instructions are to be used after the turbosupercharger has been removed from the engine.

(1) These instructions will be used to make sure the reasons given on the repair tag are correct, and to find out if there are other problems with the turbosupercharger.

(2) If no repair tag is attached, the instructions can be used to find out what is wrong so it can be repaired.

b. Inspection. Inspect the turbosupercharger for the problems listed below, and then go to the Troubleshooting Table to find out the cause and what corrective action to take.

2-2. INSPECTION.

a. Inspect the Turbosupercharger for:

(1) Broken, damaged, or missing studs.

(2) Cracked or broken mounting legs or oil drain tube.

NOTE

Mark any damage found for repair and continue to inspect for the following items (3) through (10). If no additional problems are found, the turbosupercharger should then be cleaned, damaged items replaced, and the unit returned to the supply system.

(3) Cracked or damaged compressor housing, turbine housing, or center housing.

(4) A lot of oil in the compressor housing air outlet.

NOTE

A trace of oil in this area is normal.

(5) A lot of oil in the turbine housing exhaust inlets, with heavy oily soot deposits on the turbine wheel.

(6) Heavy oily soot deposits on the turbine wheel, with no oil in the turbine housing exhaust inlets.

(7) Damaged or eroded (worn) compressor wheel blades.

NOTE

If the compressor wheel blades are worn, look for dust or sand deposits in the compressor housing inlet and outlet openings.

(8) Peened or feathered edges on compressor wheel or turbine wheel blade tips.

(9) Compressor wheel or turbine wheel does not turn freely when spun by hand.

(10) Compressor wheel or turbine wheel appears very loose when moved in and out or up and down by hand, accompanied by excessive noise.

NOTE

If this apparent loose condition is found, press the turbine wheel and compressor wheels in opposite directions, up and down as far as possible, with the fingers. Rock them back and forth and listen for a rubbing sound. Also press the compressor wheel and turbine wheel in as far as possible, rock back and forth, and listen for a rubbing sound.

b. Corrective Action. Refer to table 2-1 (page 2-2).

Table 2-1. Troubleshooting

PROBLEM

PROBABLE CAUSE

CORRECTIVE ACTION

1. A lot of oil in the compressor housing air outlet.

Worn or damaged spacer rings.

Disassemble and repair turbosupercharger. Refer to page 3-1.

2. A lot of oil in the turbine housing exhaust inlets, with heavy oily soot deposits on the turbine wheel.

Worn engine piston rings and/or bearings.

Continue the troubleshooting outlined below. If no other problems are found, clean the turbosupercharger and return to the supply system.

3. Heavy, oily soot deposits on the turbine wheel, with no oil in the turbine housing exhaust inlets.

Worn or damaged seal ring.

NOTE

Heavy soot deposits are generally caused by excessive engine idling or poor combustion.

Disassemble and repair turbosupercharger. Refer to page 3-1.

4. Damaged or worn compressor wheel blades.

Foreign object striking blades or leaking engine induction system.

Disassemble and repair turbosupercharger. Refer to page 3-1.

5. Peened or feathered edges on compressor wheel or turbine wheel blade tips.

Worn sleeve bearings.

Disassemble and repair turbosupercharger. Refer to page 3-1.

6. Compressor wheel and turbine wheels do not turn freely when spun by hand.

Damaged compressor wheel or turbine wheel. Excessive dirt build-up in compressor housing or turbine housing. Excessive carbon build-up behind compressor wheel.

Disassemble and repair turbosupercharger. Refer to page 3-1.

Table 2-1. Troubleshooting - Continued.

PROBLEM

PROBABLE CAUSE

CORRECTIVE ACTION

7. Compressor wheel and turbine wheels appear very loose when moved in and out or up and down by hand, evidenced by excessive noise.

Worn sleeve bearings, thrust ring, or thrust bearing.

Disassemble and repair turbosupercharger. Refer to page 3-1.

8. Compressor wheel and turbine wheels turn freely, without binding or rubbing, when spun by hand.

a. Check Radial Clearance.

If necessary remove mounting leg before removing drain tube.

- (1) Using 9/16 inch double offset box wrench, remove two bolts and lockwashers (A).
- (2) Remove oil drain tube (B).
- (3) Remove and discard gasket (C).
- (4) Position a dial indicator (D) on mounting leg (or any flat surface) so that the plunger extends through the oil drain hole and contacts the turbine wheel shaft.
- (5) Apply equal pressure to the compressor wheel and turbine wheel to move the turbine wheel shaft away from the indicator plunger.
- (6) Set the dial indicator to zero.
- (7) Apply equal pressure to the compressor wheel and turbine wheels to move the turbine wheel shaft as far as possible toward the indicator plunger. Note radial clearance on indicator dial.

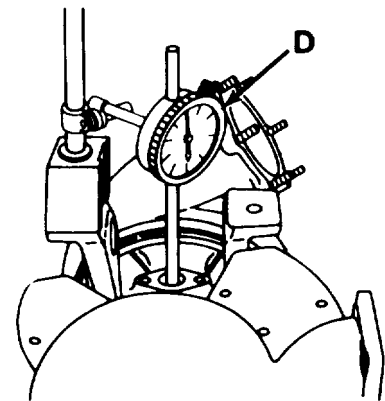
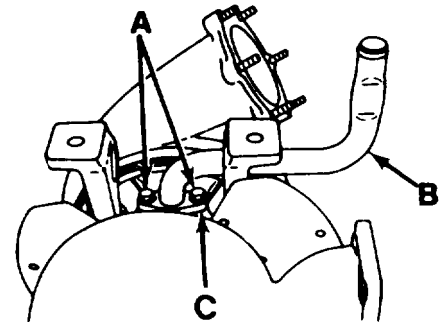

NOTE

Verify that the reading is the maximum obtainable by rotating the wheels slightly in both directions while applying pressure.

Table 2-1. Troubleshooting - Continued.

- (8) Apply equal pressure to the compressor wheel and turbine wheels to move the turbine wheel shaft as far as possible away from the indicator plunger. The indicator pointer should return to zero.
- (9) Repeat steps (5) through (8) to verify the indicator reading.
- (10) If the maximum radial clearance is less than 0.003 inch (0.076 mm) or greater than 0.006 inch (0.152 mm), repair the turbosupercharger. Refer to page 3-1.
- (11) If the maximum radial clearance is 0.003 inch (0.076 mm) to 0.006 inch (0.152 mm), proceed to b. below.

b. Check End Play.

- (1) Clean the turbine wheel hub. Attach a dial indicator (A) to the turbine housing (or any flat surface) so that the plunger rests on the turbine wheel hub (B).
- (2) Push the turbine wheel down as far as possible.
- (3) Set the dial indicator to zero.
- (4) Pull the turbine wheel up as far as possible. Note end play on indicator dial.
- (5) Repeat steps (2) through (4) to verify the indicator reading.
- (6) If maximum end play is less than 0.004 inch (0.102 mm) or greater than 0.009 inch (0.229 mm), repair the turbosupercharger. Refer to page 3-1.

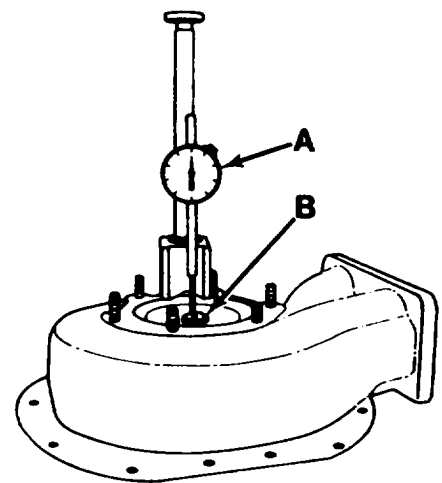

- (7) If maximum end play is 0.004 inch (0.102 mm) to 0.009 inch (0.229 mm), and no other damage is evident:
 - (a) Using new gasket (C), install oil drain tube (D).
 - (b) Secure oil drain tube with two bolts and lockwashers (E). Using 9/16 inch socket and 0 to 300 pound-inch, 1/2 inch drive torque wrench, tighten bolts to 275 pound-inches (31 N-m).
- (8) Clean unit and return to supply system.

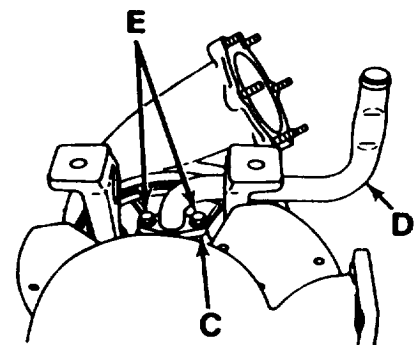

Section II. GENERAL MAINTENANCE

2-3. GENERAL.

Special tools, repair parts, and equipment over and above those available to the using organization are supplied to direct and general support units for maintaining and repairing the material.

2-4. COMMON TOOLS AND EQUIPMENT.

For authorized common tools and equipment refer to the Modified Table of Organization and Equipment (MTOE) applicable to your unit.

2-5. SPECIAL TOOLS.

A thread tap and screw thread inserter are required for repair of these turbo-superchargers.

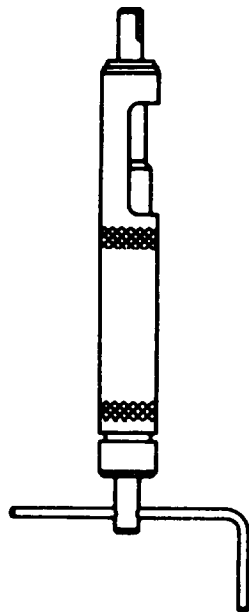

**SCREW THREAD
INSERTER,
PART NO. 3551-5**



**THREAD
TAP
HEIL-COIL
PART NO.
5CBB**

2-6. IMPROVISED TOOLS.

The holding fixture shown below applies only to direct and general support units to enable these maintenance organizations to fabricate it locally. It is of chief value to units engaged in repairing a large number of similar components. However, it is not essential for repair and is not available for issue.

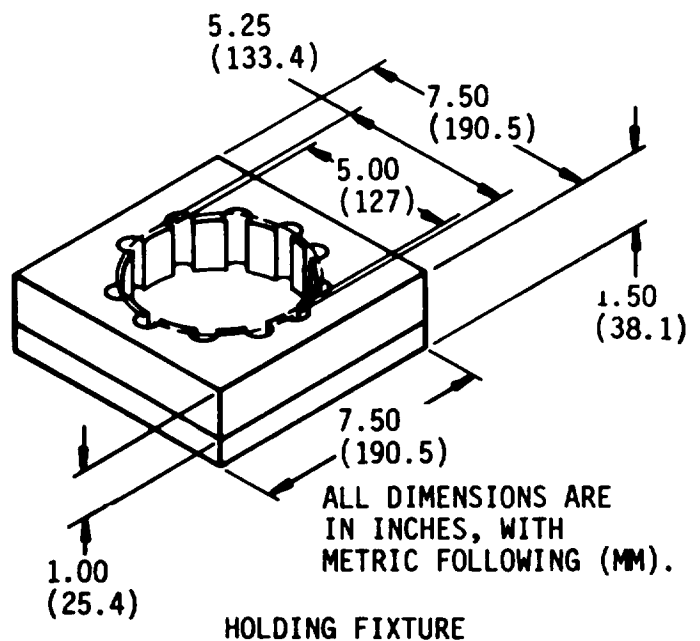

NOTE

Fabricate from hard wood or aluminum. Drill eleven 0.375 inch (9.5 mm) holes equally spaced on the 5.25 inch (133.4 mm) diameter. Cut out 5.00 inch (127 mm) circle. Bottom block is solid. Assemble top and bottom blocks with screws or bolts.

2-7. REPAIR PARTS.

Repair parts are listed and illustrated in Appendix B of this manual.

CHAPTER 3

MAINTENANCE OPERATIONS

Section I. GENERAL

3-1. PURPOSE.

This chapter provides instructions for disassembly, cleaning, inspection, re-

pair, and reassembly of the turbosupercharger. The step-by-step procedures are accompanied by illustrations which are keyed to the instructions.

Section II. DISASSEMBLY

3-2. REPAIR EQUIPMENT.

Listed below are the shop equipment, common tools, expendable materials, and repair parts required for repair of the turbosupercharger.

a. Shop Equipment.

(1) Arbor press and support plates

(2) Vise, 6-inch

(3) Workbench

b. Common Tools.

(1) Box wrench, angular offset, 13/16 inch opening, 12 point

(2) Box wrench, double offset, 9/16 inch opening, 6 or 12 point

(3) Dial indicator

(4) Extension, 5-inch, 1/2 inch square drive

(5) Hammer (plastic insert)

(6) Hand file

(7) Handle, socket wrench (speeder), 16 inches long

(8) Holding fixture (improvised seal)

(9) Internal retaining ring pliers, 7 inches long

(10) Micrometer, 0.00 to 1.00 inch

(11) Micrometer, 1.00 to 2.00 inch

(12) Ratchet handle, 9-1/2 inches long, 1/2 inch square drive

(13) Scriber

(14) Socket, 7/16 inch opening (deep), 1/2 inch square drive, 6 or 12 point

(15) Socket, 1/2 inch opening, 1/2 inch square drive, 6 or 12 point

(16) Socket, 9/16 inch opening, 1/2 inch square drive, 6 or 12 point

(17) Stud remover and setter, 1/2 inch drive, 1/4 to 3/4 inch diameter

(18) Telescope gage, 0.3125 to 0.5000 inch

(19) Telescope gage, 0.5000 to 0.7500 inch

(20) Telescope gage, 0.7500 to 1.2500 inch

(21) Thickness gage (feeler), 0.0015 to 0.025 inch blades

(22) Torque wrench, 0 to 300 pound-inches, 1/2 inch square drive

(23) Vernier calipers

c. Expendable Materials.

(1) Drycleaning solvent (P-D-680, Type II)

(2) Corrosion inhibiting, heat-cured, solid film lubricant (MIL-L-46010)

(3) Preservative general purpose lubrication oil (VV-L-800)

(4) Lint-free cloths

d. Repair Parts. Requisition Parts Kit, Part No. 409448 (page B-9).

3-3. DISASSEMBLY.

REMOVE MOUNTING LEGS AND OIL DRAIN TUBE

TOOLS :

- 9/16 inch, double offset box wrench
- 9/16 inch, 1/2 inch drive socket
- 1/2 inch drive ratchet handle
- 1/2 inch drive, 5-inch long extension

REMOVAL :

1. Using 9/16 inch socket, ratchet handle, and extension, remove two bolts and lockwashers (A).
2. Remove mounting leg (B).

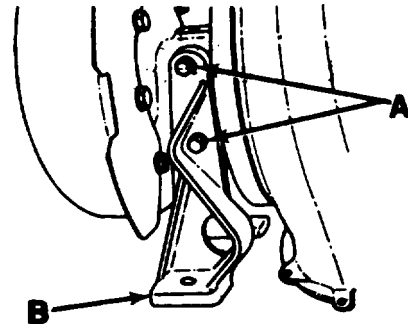

3. Using 9/16 inch socket, ratchet handle, and extension, remove two bolts and lockwashers (C) from opposite mounting leg.
4. Remove mounting leg (D).

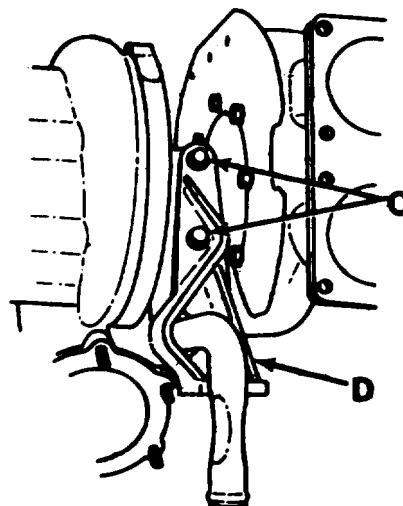

5. Using 9/16 inch double offset boxwrench, remove two bolts and lockwashers (E).
6. Remove oil drain tube (F).
7. Remove and discard gasket (G).

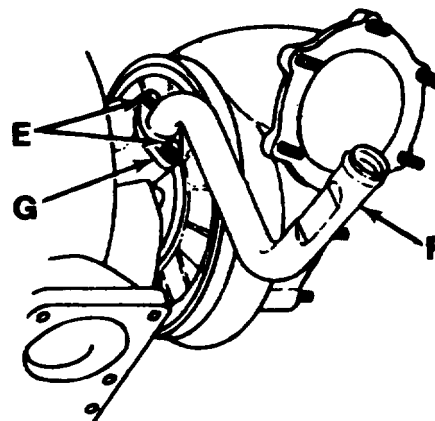

DISASSEMBLY-Continued.

REMOVE COMPRESSOR HOUSING

TOOLS:

- Scriber
- 7/16 inch, 1/2 inch drive, deep socket
- Socket wrench handle (speeder)

REMOVAL:

1. Using scriber, scribe alignment marks on compressor housing (A), clamp (B), and backplate (C). If your turbosupercharger is a newer model, alignment marks will be cast into the flanges of the compressor and bearing housings. Take careful note of the alignment marks to ensure proper housing alignment during assembly.
2. Using 7/16 inch socket and speeder, loosen nut (D) and move clamp (B) toward center housing (E).

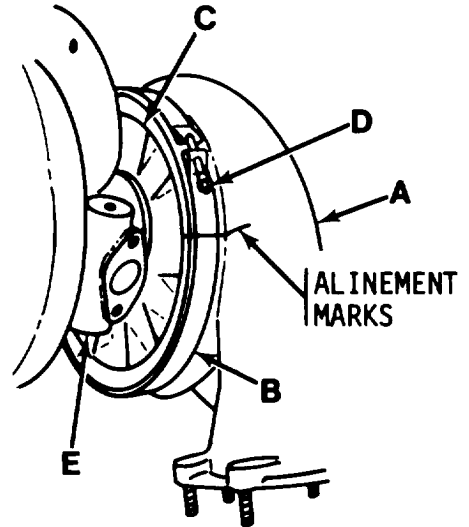

CAUTION

Lift compressor housing carefully to prevent damage to compressor wheel.

3. Remove compressor housing (A).
4. Remove and discard preformed packing ("O" ring) (F).
5. Remove clamp (B).

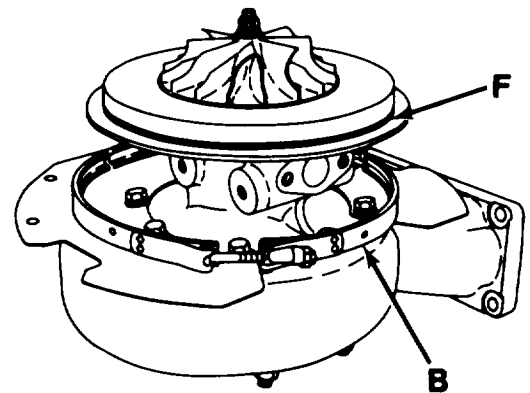

DISASSEMBLY—Continued.

REMOVE HEAT SHIELD AND CENTER HOUSING

TOOLS :

Scriber
9/16 inch, double offset box wrench

REMOVAL :

1. Using scribe, scribe alignment marks on center housing (A) and turbine housing (B).
2. On part number 11669107-1 and 11669107-2 turbosuperchargers only, scribe alignment marks on heat shield (D) and turbine housing (B).
3. Using 9/16 inch double offset box wrench, remove eight bolts and lockwashers (C).
4. Remove heat shield (D).

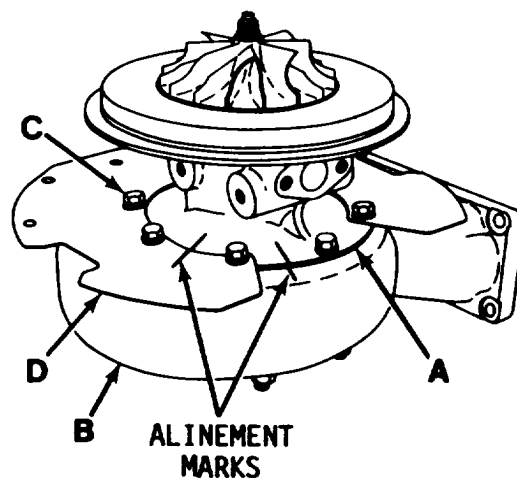

5. Lift center housing (A) with compressor wheel and turbine wheel from turbine housing (B).
6. Remove six nuts (E) from engine exhaust mounting studs on turbine housing.

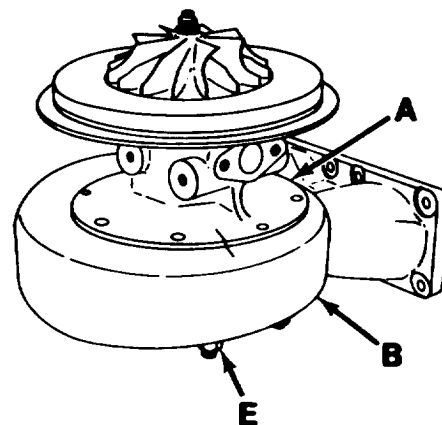

DISASSEMBLY—Continued.REMOVE IMPELLER NUT (COMPRESSOR WHEEL NUT)

TOOLS:

13/16 inch, angular offset box wrench, 12 point
 1/2 inch, 1/2 inch drive socket, 12 point
 1/2 inch drive ratchet handle
 Holding fixture (improvised)

REMOVAL :

1. Place a 13/16 inch angular 12 point box wrench in vise. Position wrench to hold turbine wheel hub.
2. Place turbine wheel hub in box wrench and hold in position (A).
3. Using 1/2 inch socket and ratchet handle (B) remove compressor wheel nut (C) from turbine wheel shaft.
4. On turbine wheel hubs that cannot be held with a box wrench (because of factory balancing), use improvised holding fixture (D) to keep turbine wheel from turning. Refer to page 2-5 for fabrication instructions.
5. Using 1/2 inch socket and ratchet handle (B), remove nut (C) from turbine wheel shaft.

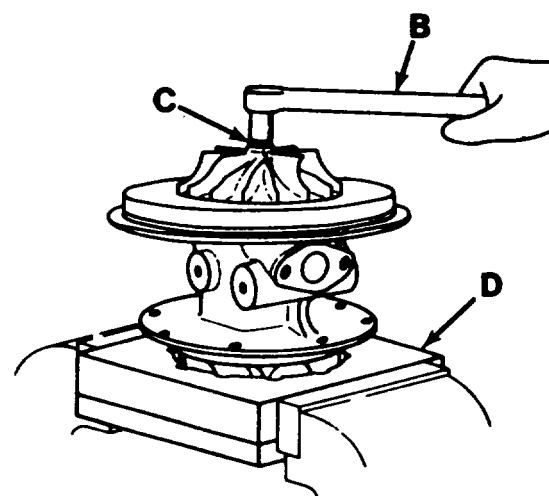
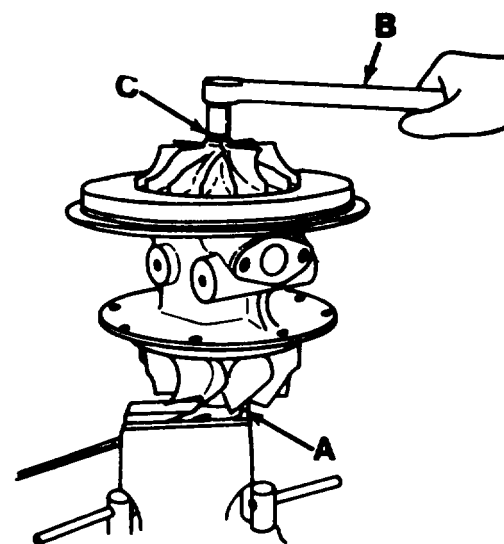
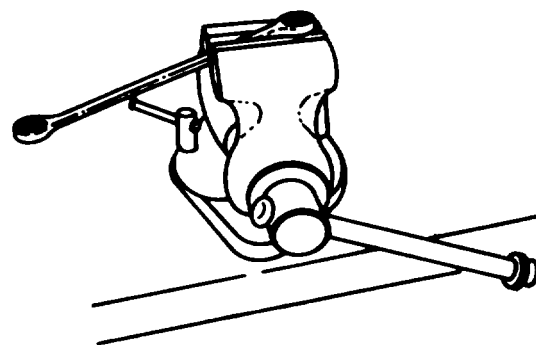

DISASSEMBLY—Continued.

REMOVE COMPRESSOR WHEEL, TURBINE WHEEL, AND SHROUD WHEEL (SHROUD)

TOOLS :

Arbor press
Support plates
Wood block

REMOVAL :

1. Place center housing (A) in arbor press (B), with turbine wheel protected by suitable support plates (C) and wood block (D).
2. Press turbine wheel shaft (E) until turbine wheel (F) drops on wood block (D).
3. Lift arbor and remove compressor wheel (G). Remove center housing and turbine wheel from arbor press.

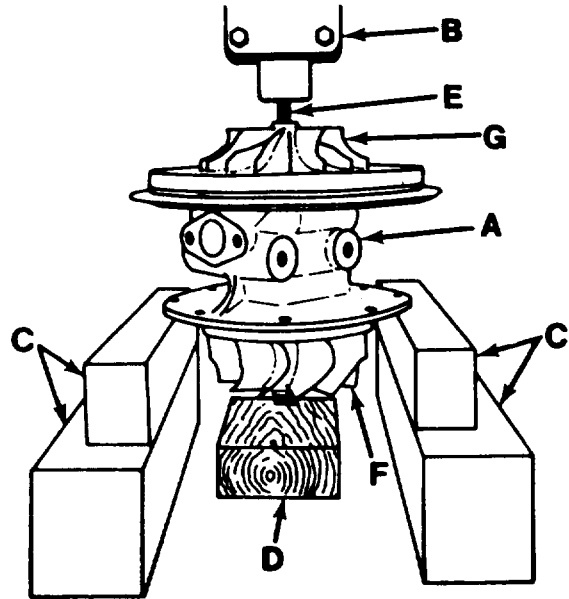

4. Remove turbine wheel (F) and shroud (H) from center housing (A).

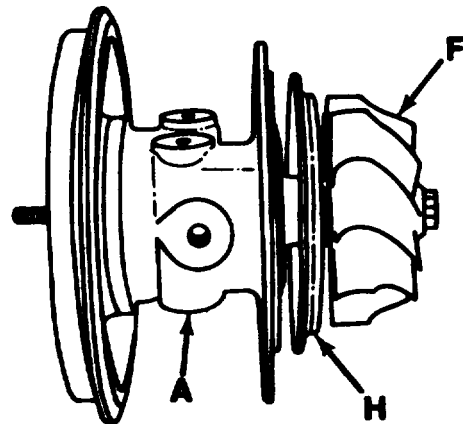

DISASSEMBLY—Continued.REMOVE SEAL RING, BACKPLATE, AND THRUST SPACER

TOOLS:

9/16 inch, double offset box wrench
Plastic insert hammer

REMOVAL:

- Using fingers, remove and discard seal ring (A) from groove in turbine wheel shaft (B).

- Using 9/16 inch box wrench, remove four bolts and flat washers (C) from center housing.

- Tap the backplate (D) with a plastic insert hammer and remove it from the center housing (E).

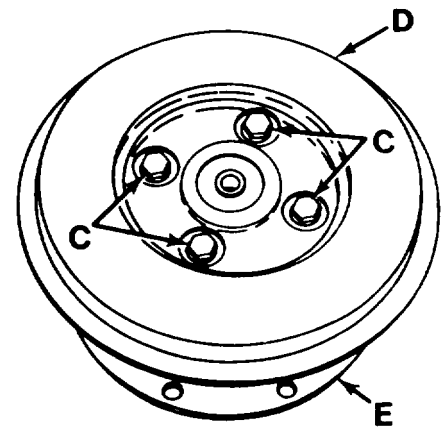

- Remove thrust spacer (F) from backplate (D).

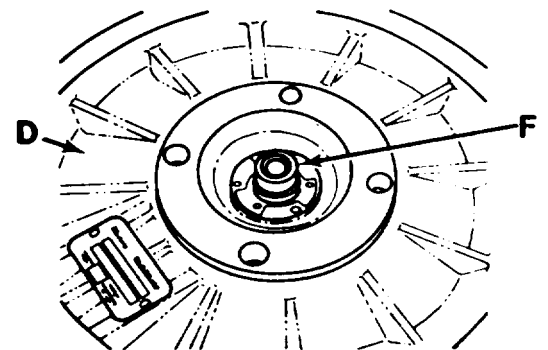

- Using fingers, remove and discard two spacer rings (G) from thrust spacer (F).

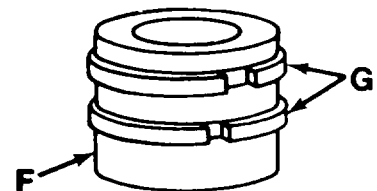

DISASSEMBLY—Continued.

REMOVE THRUST RING, THRUST BEARING, SLEEVE BEARING, AND THRUST WASHER

REMOVAL:

1. Remove thrust ring (A) .
2. Remove and discard ring seal ("O" ring) (B).

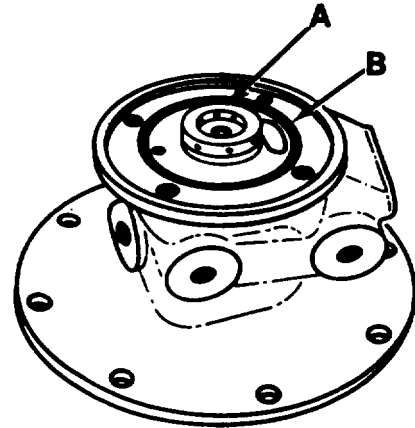

3. Remove and discard thrust bearing (C) .

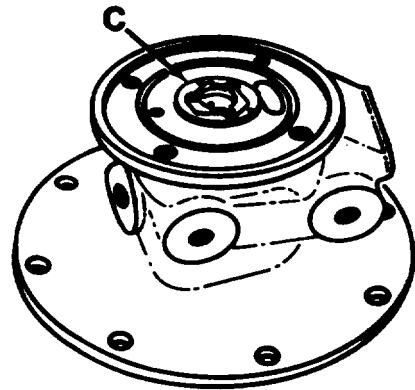

4. Remove and discard sleeve bearing (D) from center housing bore.
5. Remove and discard thrust washer (E) from housing bore.

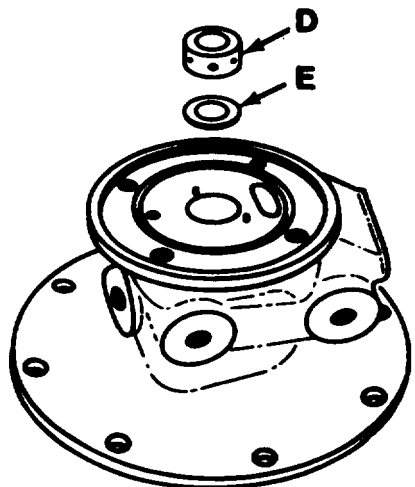

DISASSEMBLY-Continued.

REMOVE RETAINING RINGS , THRUST WASHER, AND SLEEVE BEARING

TOOLS :

Internal retaining ring pliers

REMOVAL:

1. Using internal retaining ring pliers (A), remove and discard retaining ring (B) from housing bore.

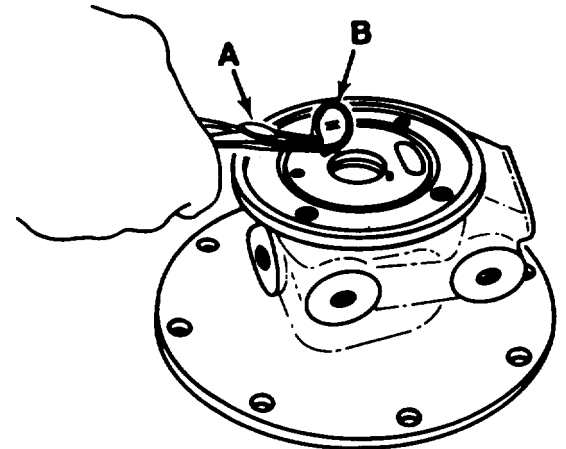

2. Turn center housing over (180°). Using retaining ring pliers (A), remove and discard retaining ring (C) from housing bore.

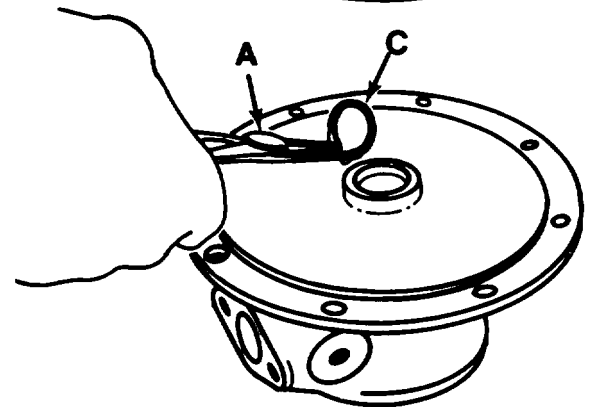

3. Remove and discard thrust washer (D) from housing bore.
4. Remove and discard sleeve bearing (E) from housing bore.
5. Using retaining ring pliers, remove and discard retaining ring (F) from housing bore.

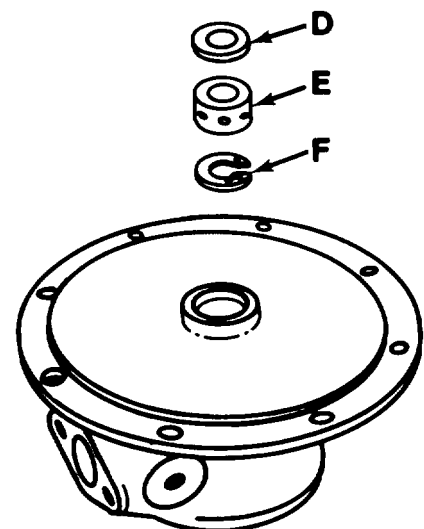

DISASSEMBLY—Continued.

REMOVE DUST DETECTOR COVER, PACKING WITH RETAINER, CHAIN FASTENER, CHAIN "S" HOOK, AND CHAIN

Tools:

- 1/2 inch, 1/2 inch drive socket
- 1/2 inch drive ratchet handle

NOTE

This procedure applies to "clean air" turbosupercharger only.

REMOVAL :

1. Using 1/2 inch socket and ratchet handle, remove three cap screws (A), two flat washers (B), and packing with retainer (C). Discard packing with retainer.
2. Remove chain fastener (D), chain "S" hook (E), and chain (F) as an assembly.

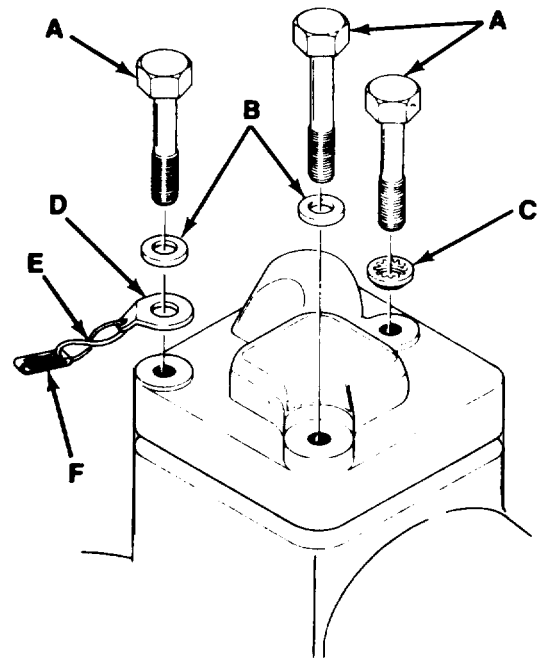

NOTE

It will not be necessary to disassemble the chain fastener, chain "S" hook, and chain unless one or more of these parts shows signs of wear or damage.

3. Remove dust detector cover (G).

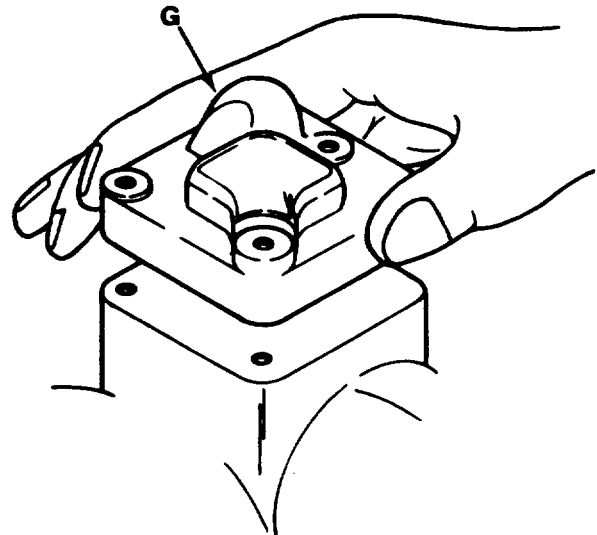

DISASSEMBLY—Continued.REMOVE PREFORMED PACKINGS, FILTER RETAINING STRAP AND FILTER FROM DUST DETECTOR COVER**NOTE**

This procedure applies to "clean air" turbosuper-charger only.

REMOVAL:

1. Remove filter retaining strap (A) and filter (6).
2. Remove and discard three preformed packings (C) from underside of dust detector cover.

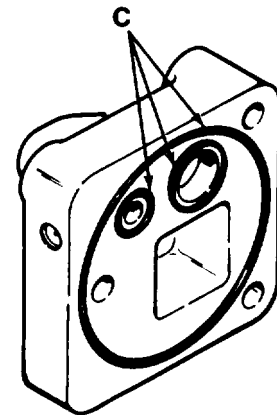
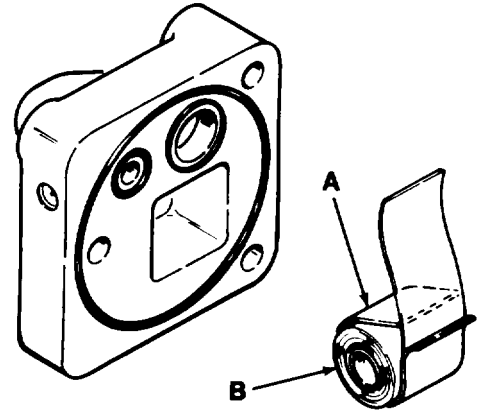
REMOVE COMPRESSOR COVER INLET AND OUTLET ADAPTERS AND PREFORMED PACKINGS

TOOLS:

9/16 inch offset box wrench
5/8 inch offset box wrench

REMOVAL:

1. Using 5/8 inch box wrench, remove compressor cover inlet adapter (A).
2. Using 9/16 inch box wrench, remove compressor cover outlet adapter (B).
3. Remove and discard two preformed packings (C).

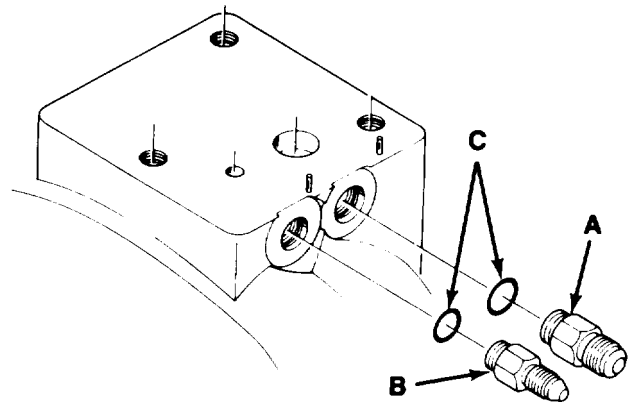

TA293544

Change 1

3-10.1

Section III. CLEANING, INSPECTION, AND REPAIR

3-4. CLEANING.

WARNING

Particles blown by compressed air are hazardous. Make certain the air stream is not directed at any person. Protect eyes and face with appropriate shields.

Remove foreign material accumulations from exterior surfaces. Remove any remaining foreign material using a clean cloth moistened in drycleaning solvent (P-D-680, Type II). Blow dry with compressed air, or wipe dry with a clean cloth. Clean all oil holes with probes. Probe the turbine end of the center housing to remove all carbonized oil.

CAUTION

Do not use caustic solution wire brush, or steel blade scraper. Use bristle brush or plastic scraper only.

INSPECT COMPRESSOR HOUSING

1. Inspect compressor housing (A) for cracks, nicks, and dents. Inspect for distorted or warped mounting flanges (B) and (C).
2. Inspect for evidence of contact or interference (D) with the compressor wheel.
3. Inspect for missing, broken, loose, or damaged studs (E). Tag loose or damaged studs for repair.
4. Replace compressor housing if cracked, or if mounting flanges are distorted. Replace if there is evidence of interference with the compressor wheel.

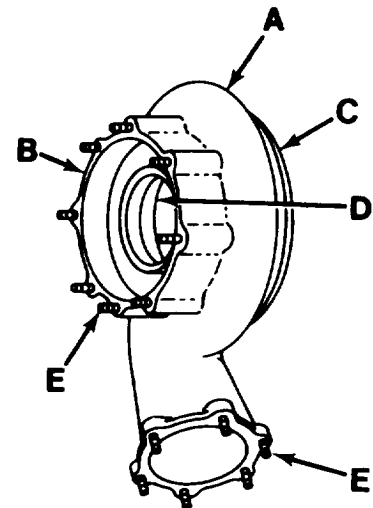

3-5. INSPECTION.

General. All parts must be thoroughly examined and inspected to determine if they are suitable for reuse in rebuild of the assembly, or whether they must be replaced with new parts.

b. Cracks. Inspect for cracks using a strong light and magnifying glass.

c. Wear or Damage. Some types of wear or damage may be detected by visual inspection, while other types require use of suitable measuring instruments and equipment. All reused parts must meet wear limit requirements.

d. Bore and Outside Diameters. When measuring bores or outside diameters, always take two measurements, about 90° apart, to account for a possible out-of-round condition.

INSPECTION-Continued.

INSPECT CLAMP

1. Inspect clamp (A) for cracks or separated welds (B).
2. Inspect nut (C) and yoke stud (D) for thread damage,
3. Replace cracked or damaged clamp or nut.

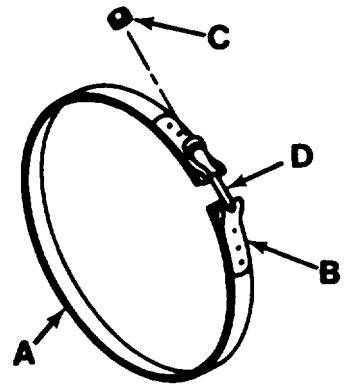

INSPECT MOUNTING LEGS AND OIL DRAIN TUBE

1. Inspect mounting legs (E) and oil drain tube (F) for cracks. Look for bent or crushed drain tube (F).
2. Inspect weld at tube and flange joint.
3. Replace cracked mounting legs. Replace cracked, bent, or crushed oil drain tube.

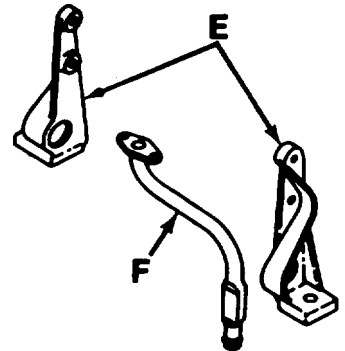

INSPECT HEAT SHIELD

1. Inspect heat shield (G) for cracks and deformation. Tag deformed heat shield for possible repair.
2. Replace cracked heat shield

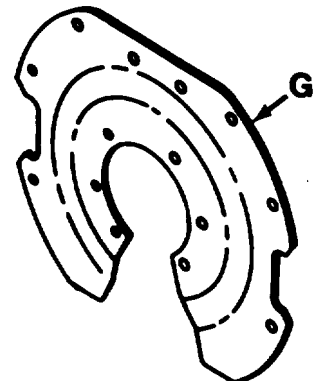

INSPECT TURBINE HOUSING

1. Inspect turbine housing (H) for cracks. Look for distorted or warped mounting flanges (J), (K), and (L).
2. Inspect for evidence of contact or interference (M) with the turbine wheel.
3. Inspect for missing, broken, loose, or damaged studs (N). Tag loose or damaged studs for repair. Inspect tapped holes (P) for thread damage.
4. Replace turbine housing if cracked, or if mounting flanges are distorted.

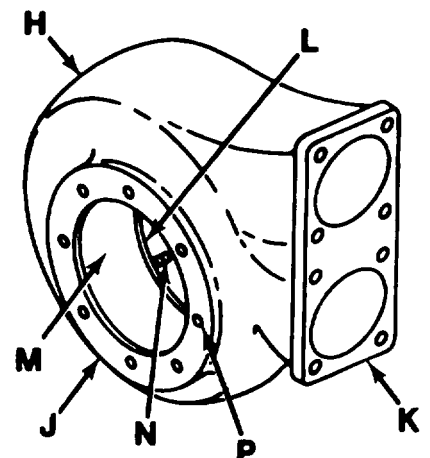

INSPECTION-Continued.

INSPECT COMPRESSOR WHEEL AND NUT

TOOLS:

0.3125 to 0.5000 inch telescope gage
0.(X) to 1.00 inch micrometer

1. Inspect compressor wheel nut (A) for thread damage or deformation.

CAUTION

Cracked compressor wheel blades will break during operation and-cause failure..

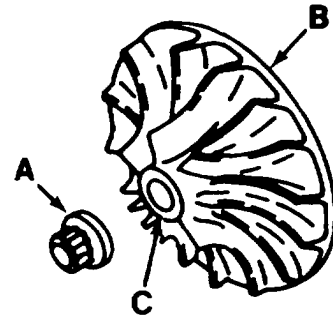

2. Inspect compressor wheel (B) for cracked, broken, bent, eroded, or missing blades. Inspect rear surface of compressor wheel for evidence of wear or scoring.
3. Measure and record compressor wheel bore diameter (C) using telescope gage and micrometer.
4. Replace damaged compressor wheel nut. Replace compressor wheel if damaged, or if bore diameter exceeds 0.3739 inch (9.497 mm).

INSPECT BACKPLATE

TOOLS:

0.5000 to 0.7500 Inch telescope gage
0.00 to 1.00 inch micrometer

1. Inspect backplate (D) for cracks. Inspect mounting flange and machined mating surface for distortion or warpage.
2. Flush oil hole with solvent. Solvent must enter through hole (E) and flow freely through three holes (F).
3. Inspect thrust bearing (G) for evidence of overheating, scoring, or looseness. The three thrust bearing pads (H) must be smooth and flat. All three pads (H) must be parallel to surface (J) within 0.0010 Inch (0.025 mm). Surface (J) flatness must not exceed 0.0005 inch total indicator reading (TIR) (0.0127 mm TIR).
4. Inspect bore (K) for scratches or scoring. Measure bore diameter (K) using telescope gage and micrometer. Replace backplate if bore diameter exceeds 0.6885 inch (17.49 mm).
5. Measure depth from surface (J) to thrust bearing pad (L). Replace backplate if depth exceeds 0.3980 inch (10.11 mm).
6. Replace backplate if cracked, distorted, or does not meet wear limit requirements.

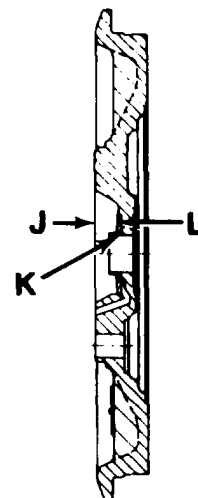
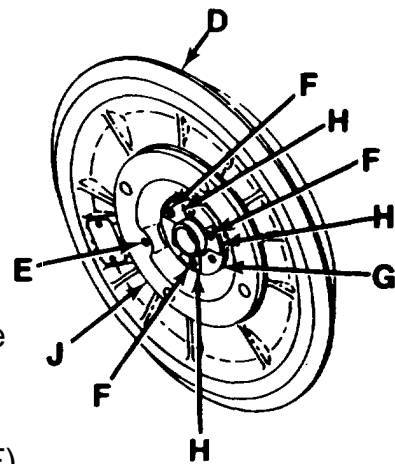

TA097818

INSPECTION-Continued.

INSPECT THRUST SPACER

TOOLS:

- 0.3125 to 0.5000 inch telescope gage
- 0.00 to 1.00 inch micrometer
- 0.0015 to 0.025 inch blade thickness gage (feeler)

1. Inspect thrust spacer (A) for cracks, scoring, galling, chipped edges or wear on end surfaces. End surfaces must be parallel within 0.0001 inch TIR (0.0025 mm TIR).
2. Measure bore diameter (C) using telescope gage and micrometer. Replace thrust spacer if bore diameter exceeds 0.3758 inch (9.645 mm). Inspect grooves (D) for wear. Measure width of grooves (D) using thickness gage. Replace thrust spacer if groove width exceeds 0.0695 inch (1.765 mm).
3. Replace thrust spacer if damaged, has groove wear, or does not meet wear limit requirements.

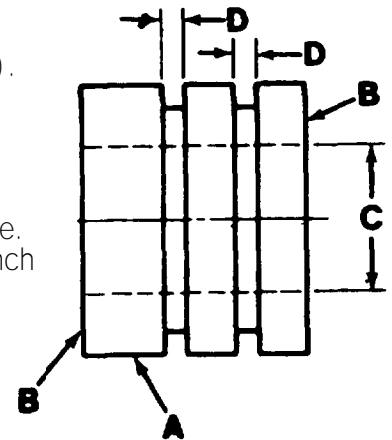
INSPECT THRUST RING

TOOLS:

- 0.00 to 1.00 inch micrometer
- 0.3125 to 0.5000 inch telescope gage

1. Inspect thrust ring (E) for scratches, scoring, and galling on inside surface (F) and bottom surface (G). Check to be certain oil passages (H) are clear. Surface (F) must be free of surface defects and have a smooth surface finish.
2. End surfaces (J) and (K) must be parallel within 0.0003 inch (0.0076 mm). Surface (F) must be parallel to surface (L) within 0.0020 inch TIR (0.0508 mm TIR).
3. Measure thickness (M) using micrometer. Replace thrust ring if thickness is less than 0.2990 inch (7.595 mm). Measure bore diameter (N) using telescope gage and micrometer. Replace thrust ring if bore diameter exceeds 0.3758 inch (9.545 mm).
4. Measure thickness (P). Replace thrust ring if thickness is less than 0.0850 inch (2.159 mm). Measure diameter (Q). Replace thrust ring if diameter is less than 1.1200 inch (28.45 mm).
5. Replace thrust ring if damaged, or does not meet wear limit requirements.

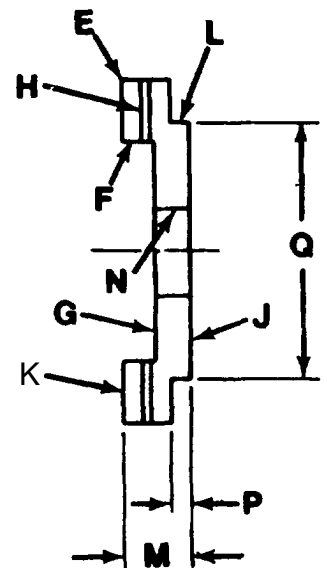

TA097819

INSPECTION—Continued.

INSPECT CENTER HOUSING

TOOLS:

- 0.7500 to 1.2500 inch telescope gage
- 0.00 to 1.00 inch micrometer
- 1.00 to 2.00 inch micrometer

1. Inspect center housing (A) for cracks, nicks, and raised metal. Inspect for distorted or warped mounting flange and machined mating surfaces. Inspect tapped holes for thread damage.
2. Flush oil holes with solvent. Solvent must enter through oil inlet hole (B) and flow freely through three holes (C).
3. Inspect sleeve bearing bores (D) for scratches, scoring, or galling.
4. Inspect for bent, cracked, or loose locating pins (E). Pins must be secure and not damaged.
5. Measure sleeve bearing bore diameters (D) using telescope gage and micrometer. Replace center housing if bore diameter exceeds 0.9832 inch (24.97 μm).
6. Measure seal ring bore diameter (F) using telescope gage and micrometer. Replace center housing if bore diameter exceeds 1.0310 inch (26.19 mm).
7. Measure step bore (G) using telescope gage and micrometer. Replace center housing if bore diameter exceeds 1.0210 inch (25.93 mm).
8. Replace center housing if damaged, or does not meet wear limit requirements.

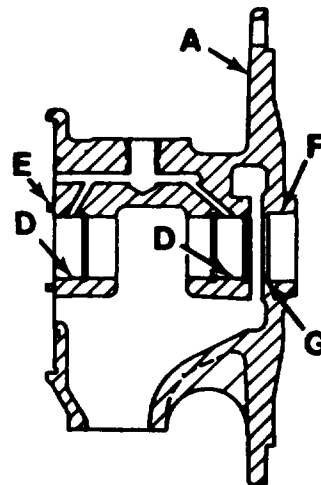
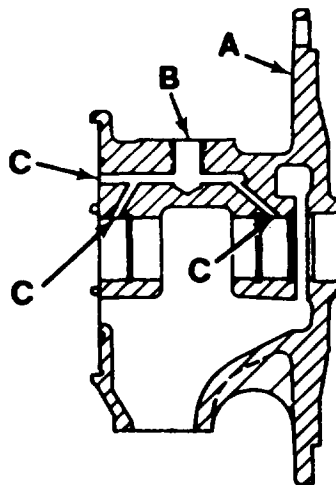

INSPECTION-Continued.INSPECT SHROUD

1. Inspect shroud (A) for cracks, nicks, and raised metal.
2. Inspect mating flange for distortion. Inspect flat face of shroud for evidence of rubbing or scoring from the turbine wheel.
3. Replace damaged shroud.

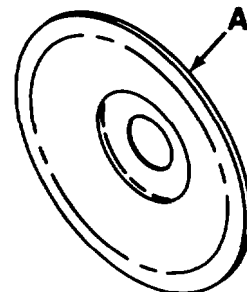
INSPECT TURBINE WHEEL

TOOLS:

- 0.00 to 1.00 inch micrometer
- 0.0015 to 0.025 inch blade thickness gage (feeler)
- Vernier calipers

CAUTION

Cracked turbine wheel blades will break during operation and cause failure.

1. Inspect turbine wheel (B) for cracked, broken, bent, eroded, or missing blades. Inspect shaft for cracks, scratches, or scoring. Inspect bearing journals and threads for damage. Inspect rear surface of turbine wheel for evidence of wear or scoring. Inspect seal ring groove (C) for wear.
2. Inspect blade tips for feather-edge or tears.
3. Measure blade tips (D) with micrometer. Replace turbine wheel if damaged, or if blade thickness is less than 0.025 inch (0.635 mm).
4. Measure seal ring groove (C) width and diameter using thickness gage and vernier calipers. Replace turbine wheel if groove width exceeds 0.0685 inch (1.7399mm) or groove diameter is less than 0.8600 inch (21.84 mm).
5. Measure shaft bearing journals (E) using micrometer. Replace turbine wheel if diameters are less than 0.6250 inch (15.875 mm).
6. Measure shaft hub diameter (F) using micrometer. Replace turbine wheel if diameter is less than 0.9950 inch (25.273 mm).

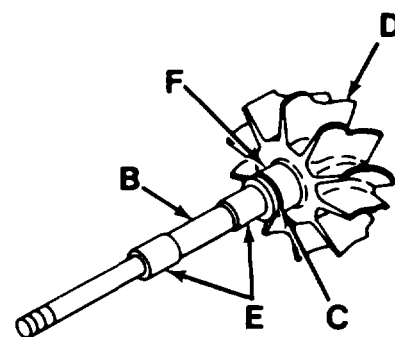

INSPECTION-Continued.

INSPECT DUST DETECTOR COVER, INLET AND OUTLET ADAPTERS, AND FILTER RETAINING STRAP

NOTE

This procedure applies to "clean air" turbosuper-charger only.

1. Inspect dust detector cover (A) for cracks, scoring of mating surface (B), and thread damage in tapped holes (C).
2. Check adapters (D) and (E) for cracks, distortion or thread damage. Ensure both are clear of obstruction.
3. Inspect filter retaining strap (F) for cracks, bends, and general serviceability.
4. Replace any of these components if damaged.

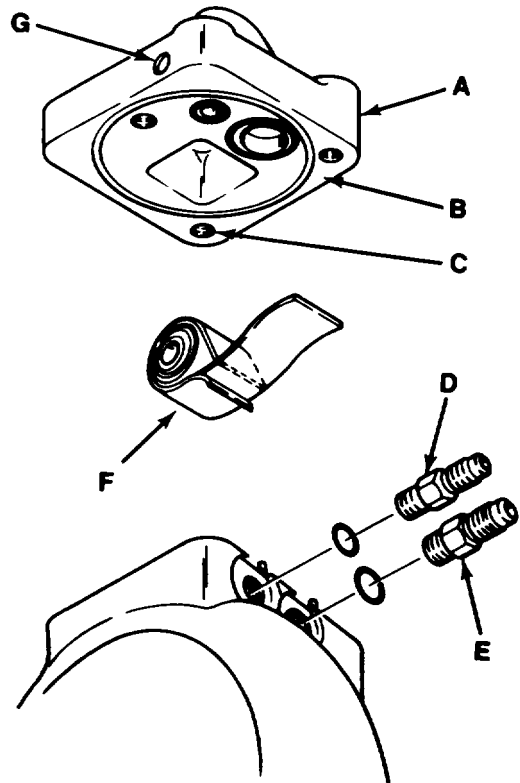

3-6. REPAIR.**REPAIR COMPRESSOR HOUSING**

TOOLS:

Hand file

1/4 to 3/4 inch diameter, 1/2 inch drive, stud remover and setter

1. Smooth small nicks or raised metal using a fine hand file.
2. Remove and discard loose or damaged stud(s) using stud remover and setter.
3. Drill a 21/64 inch (8.33 mm) hole to a depth of 7/8 inch (22.211111).
4. Tap a 5/16-18 thread using special Heli-Coil tap (Heli-Coil Part No. 5CBB).
5. Install screw thread Insert, Part No. MS21208C5-20, into threaded guide of screw thread inserter, Part No. 3551-5, by slowly turning the pilot counterclockwise until the insert is flush with the end of the inserter. Insert the pilot of the inserter into the tapped hole, with the face of the inserter resting solidly against the compressor housing. Slowly turn the pilot handle clockwise until no further resistance is felt. Remove inserter.
6. Using stud remover and setter, install coarse thread end of new stud, Part No. 400678, to a setting height of 13/16 inch (20.64 mm).

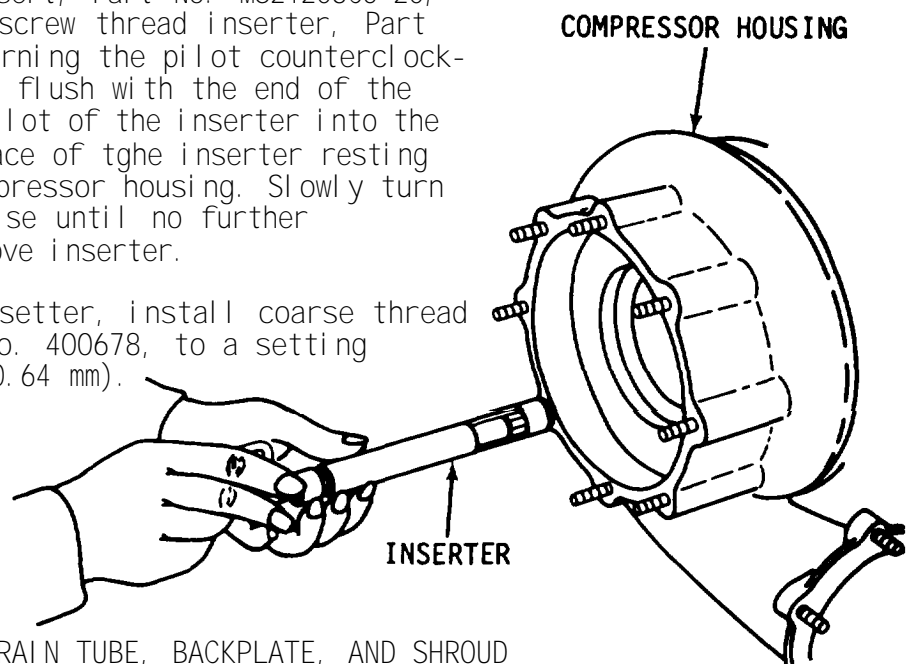
**REPAIR MOUNTING LEGS, OIL DRAIN TUBE, BACKPLATE, AND SHROUD**

TOOLS:

Hand file

Smooth small nicks and raised metal using a fine hand file.

REPAIR HEAT SHIELD

1. Straighten minor bends.
2. If heat shield cannot be restored to original configuration, it must be discarded.

REPAIR—Continued.

REPAIR TURBINE HOUSING

TOOLS :

Hand file

1/4 to 3/4 inch diameter, 1/2 inch drive, stud remover and setter

1. Smooth small nicks or raised metal using a fine hand file.
2. Remove and discard loose or damaged stud(s) (A) using stud remover and setter.
3. Using stud remover and setter, install coarse thread end of new stud, Part No. 400602-1, to a setting height of 1.00 inch (25.4 inn).
4. Repair damaged threads using a used 3/8-16NC thread tap.

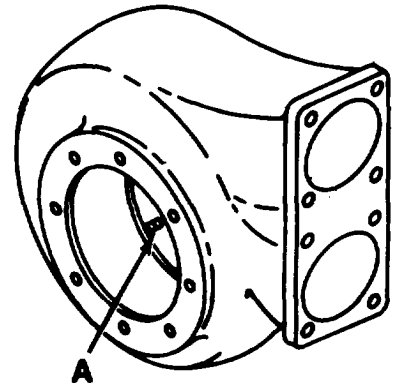

REPAIR CENTER HOUSING

TOOLS :

Hand file

1. Smooth small nicks or raised metal using a fine hand file.
2. Repair damaged oil inlet opening threads (B) using a used 1/4 NPT thread tap.
3. Repair damaged mounting leg attaching threads (C), backplate attaching threads (D), and oil drain tube attaching threads (E), using a used 3/8-16NC thread tap.

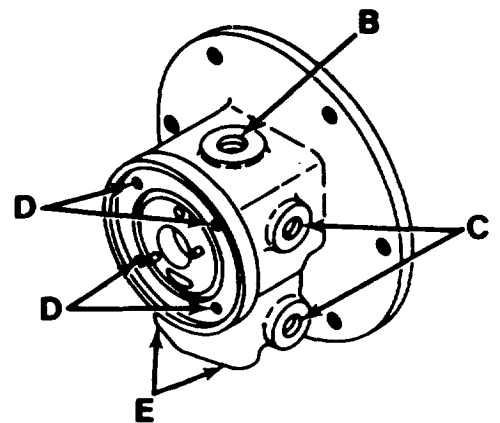

REPAIR CLAMP, COMPRESSOR WHEEL AND NUT, THRUST SPACER, THRUST RING, AND TURBINE WHEEL

1. No repairs are authorized for these parts.
2. Replace damaged components.

Section IV. ASSEMBLY

3-7. GENERAL.

Turbosuperchargers are precision products and extreme care and cleanliness must be exercised in all phases of assembly operations to insure satisfactory performance. Dirt and dust are abrasive. After cleaning, inspection, and repair, and just

before assembly, coat all parts with a light film of engine oil (OE/HDO).

3-8. PARTS KIT.

Parts Kit, Part No. 409448 (page B-9), must be requisitioned and used to assemble the turbosupercharger.

3-9 ASSEMBLY.

INSTALL RETAINING RING.

TOOLS:

Internal retaining ring pliers

NOTE

Retaining rings furnished in the Parts Kit have one flat side and one rounded side. Be certain the retaining rings are installed as instructed.

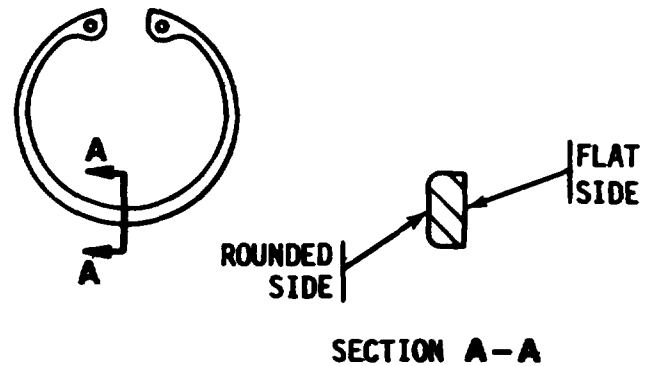

INSTALLATION:

1. Place center housing (A) on workbench with large flange (B) up.
2. Using internal retaining ring pliers (C), install retaining ring (D) in second ring groove with flat side of retaining ring down.

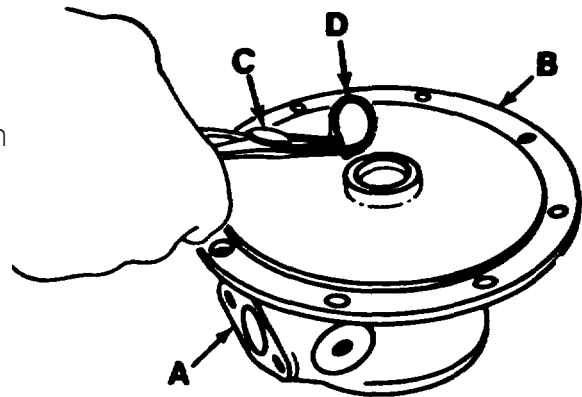

TA097824

ASSEMBLY—Continued.

INSTALL SLEEVE BEARINGS, THRUST WASHERS, AND RETAINING RINGS

TOOLS :

Internal retaining ring pliers

INSTALLATION:

1. Install sleeve bearing (A) and thrust washer (B).
2. Using retaining ring pliers, install retaining ring (C) in top groove with rounded side of retaining ring down.

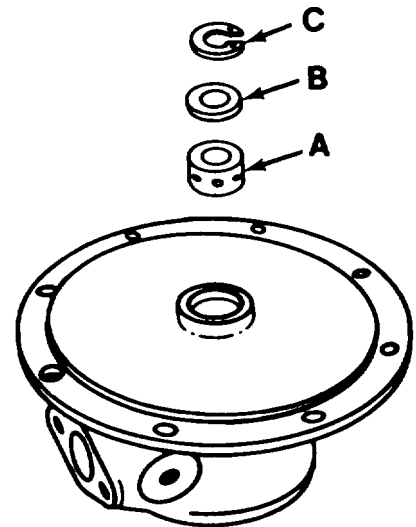

3. Turn center housing over (180°). Using retaining ring pliers (D), install retaining ring (E) in groove, with flat side down.

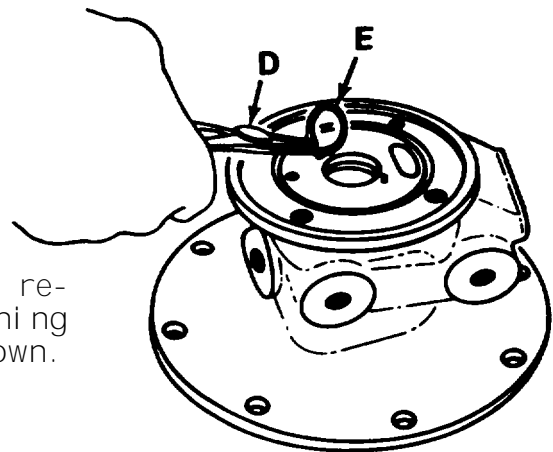

4. Install thrust washer (F) and sleeve bearing (G) in center housing bore.

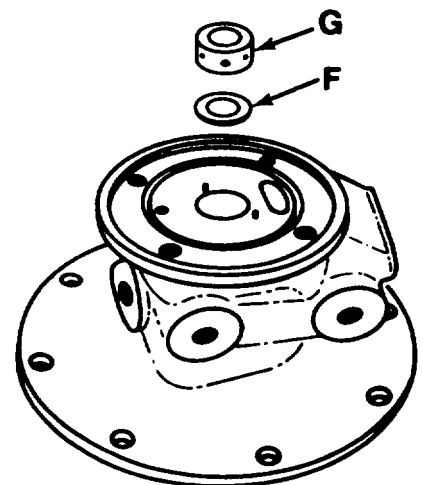

ASSEMBLY-Continued.

INSTALL SEAL RING, SHROUD, TURBINE WHEEL, AND THRUST BEARING

INSTALLATION:

CAUTION

Use care when installing the seal ring (A). It may break if spread more than necessary to clear the hub.

1. Install seal ring (A) in groove on turbine wheel hub (B).
2. Install shroud (C) on turbine wheel (B) with outside rounded surface toward flat side of turbine wheel (B).
3. Install turbine wheel (B) (with shroud) on center housing (D). Gently push the turbine wheel and shroud toward center housing using a rocking motion, until turbine wheel seal ring enters center housing bore as far as possible.

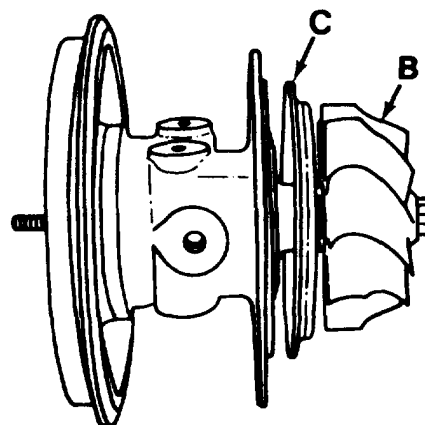
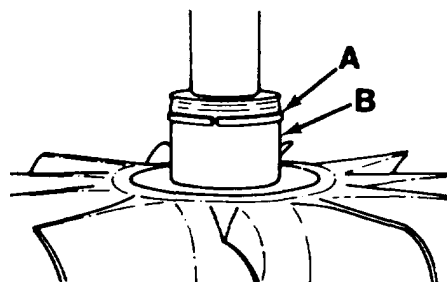

4. Hold assembled turbine wheel, shroud, and center housing (D) in upright position. Align thrust bearing locating pin holes with locating pins (E) in center housing (D) and install thrust bearing (F), with wear pad up.

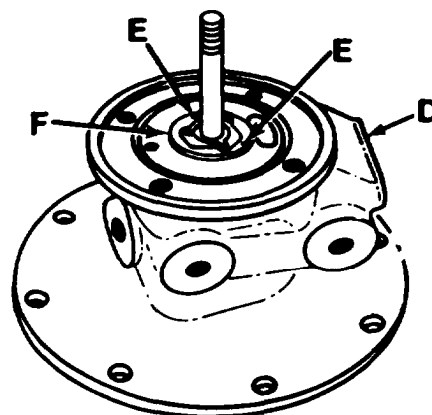

TA097826

ASSEMBLY—Continued.

INSTALL THRUST RING, "O" RING, SPACER RINGS,
AND THRUST SPACER

INSTALLATION:

1. Install thrust ring (A) with small outside diameter down.
2. Install "O" ring (B) in center housing groove.

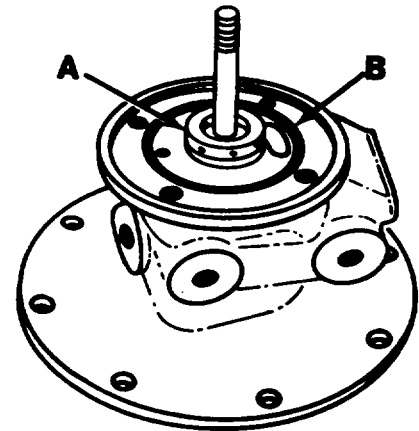

CAUTION

Use care when installing spacer rings (C). They may break if spread more than necessary to clear the thrust spacer (D).

3. Install two spacer rings (C) on thrust spacer (D) and stagger spacer ring gaps 180°

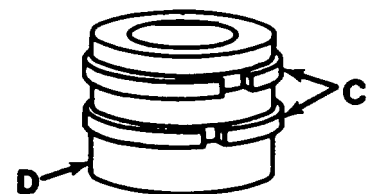

4. Install thrust spacer (with spacer rings installed) (E) in backplate (G). Long land (F) must enter backplate first.

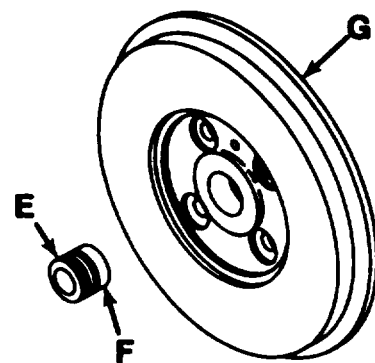

ASSEMBLY—Continued.

INSTALL BACKPLATE (WITH THRUST SPACER), COMPRESSOR WHEEL, AND NUT

TOOLS :

- 9/16 inch, 1/2 inch drive socket
- 3/16inch, angular offset box wrench, 12 point
- 1/2 inch, 1/2 inch drive socket, 12 point
- 1/2 inch drive, 0 to 300 pound-inches, torque wrench

INSTALLATION:

1. Hold thrust spacer (A) in position in backplate (B) and install backplate on center housing (C). Install four flat washers and bolts (D) and tighten using 9/16 inch socket and torque wrench. Torque tighten to 275 pound-inches (31 N-m).
2. Place a 13/16 inch angular 12 point box wrench (E) in vise. Position wrench to hold turbine wheel hub.
3. Place turbine wheel hub in box wrench (E) and hold in position. Install compressor wheel (F) on turbine wheel shaft. Install compressor wheel nut (G).
4. Using torque wrench (H), torque tighten nut to 137 pound-inches (15.5 N-m) to seat the compressor wheel against the thrust spacer (A).
5. Loosen compressor wheel nut two turns. Tighten nut one turn and note drag torque (torque required to turn nut before it seats on the compressor wheel). Tighten nut to 45 pound-inches (5 N-m) above drag torque.

NOTE

A sharp increase in torque will be noted when the nut bottoms against the compressor wheel.

6. Tighten nut to final position by pulling the wrench through an angle of 110° beyond the 45 pound-inches (5 Nm) torque point to attain proper shaft stretch.

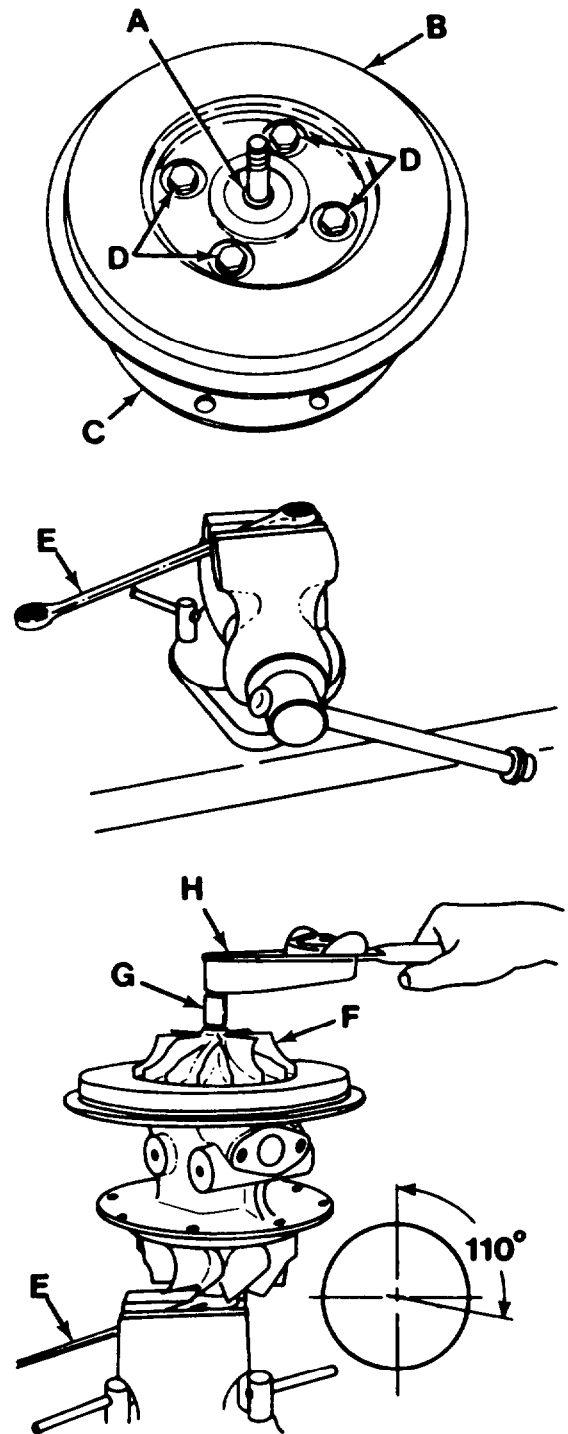

TA097828

ASSEMBLY—Continued.

7. On turbine wheel hubs that cannot be held with a box wrench (because of factory balancing), use improvised holding fixture (A) to keep turbine wheel from turning. Install compressor wheel (B) and nut (C) and torque tighten as in steps 4 through 6 above.

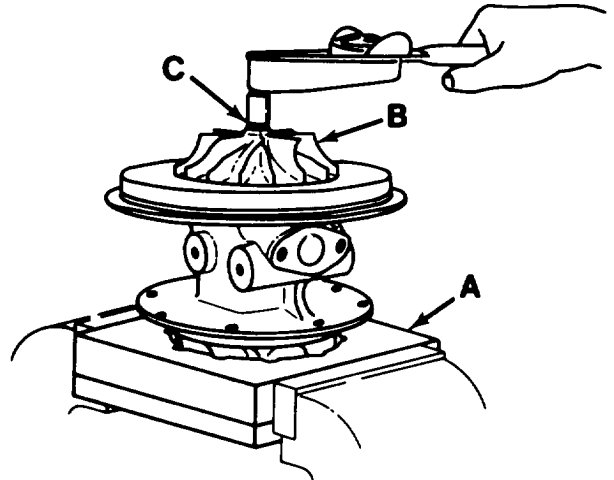

INSTALL CENTER HOUSING, HEAT SHIELD, AND COMPRESSOR HOUSING

TOOLS :

9/16 inch, 1/2 inch drive socket
 7/16 inch, 1/2 inch drive deep socket
 Socket wrench handle (speeder)
 1/2 inch drive, 0 to 300 pound-
 inches, torque wrench

NOTE

Table 3-1 provided information for proper indexing of the turbine and compressor housings according to engine model and mounting location. Table 3-1 applies to both "clean air" and standard turbosuperchargers.

INSTALLATION:

1. Place turbine housing (A) on bench with studs down.
2. Aline alinement marks scribed during disassembly and install center housing (B) on turbine housing (A). If alinement marks cannot be located, or if either housing has been replaced, refer to Table 3-1 to determine proper housing position.

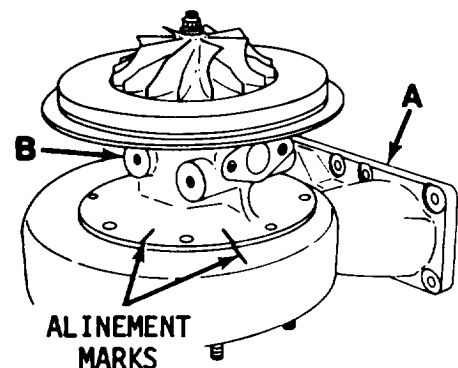

ASSEMBLY-Continued.

INSTALL CENTER HOUSING, HEAT SHIELD, AND
COMPRESSOR HOUSING - CONTINUED

3. Align alignment marks scribed during disassembly and install heat shield (c)

NOTE

If the turbosupercharger is to be used on engine models AVDS-1790-2DR the heat shield is not used.

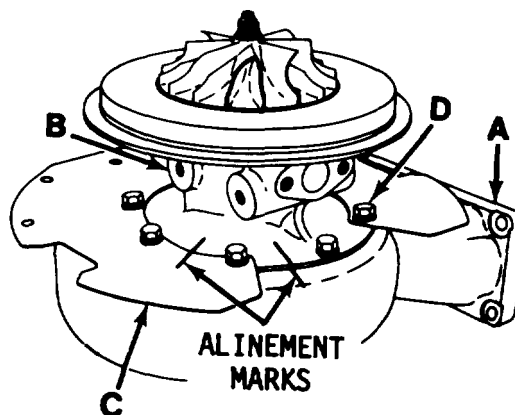

4. Apply a light coat of corrosion inhibiting, heat cured, solid film lubricant (MIL-L-46010) on bolts. Secure center housing (B) and heat shield (C) to turbine housing (A) with eight lockwashers and bolts. Torque bolts to 275 pound-inches (31 N.m) using 9/16 inch socket and torque wrench.
5. Place clamp (O) over backplate (E) and on heat shield (F).
6. Install "O" ring (G) on backplate (E).

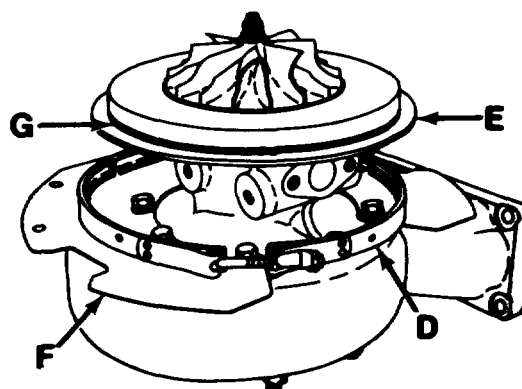

ASSEMBLY—Continued.

7. Align alignment marks and install compressor housing (H) on backplate (E). Align alignment marks and position clamp (D) backplate and compressor housing flanges. If your turbosupercharger is a newer model, alignment marks will be cast into the flanges of the compressor and center housings, and the marks you noted during disassembly should be matched. See page 3-3.

NOTE

If you cannot locate the alignment marks, or if you are otherwise unsure of the indexing of the housings, consult Table 3-1.

8. Install and tighten nut (J) to 60 pound-inches (6.75 N.m) using 7/16 inch deep socket and torque wrench.

NOTE

Tap clamp (D) lightly while tightening nut (J) to seat clamp on flanges.

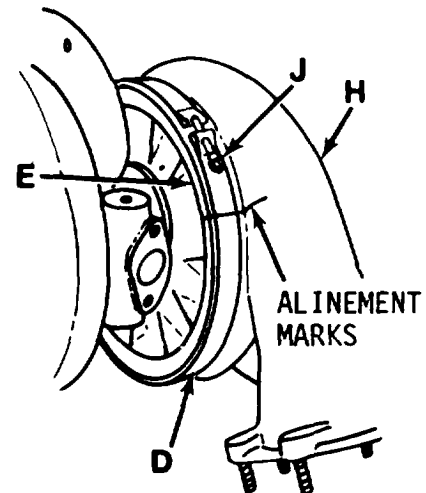
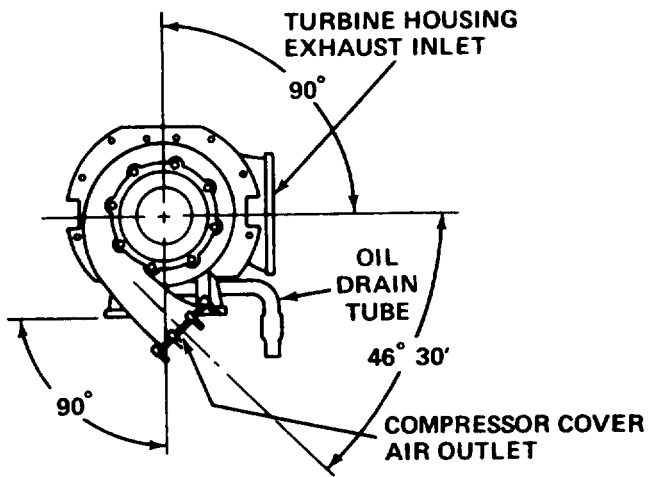

Table 3-1. Housing alignment.

Engine Models AVDS-1790-2A, AVDS-1790-2C, AVDS-1790-2CA, AVDS-1790-2D and AVDS-1790-2DA.



Alignment marks: Compressor Cover - D,
Bearing housing - A

LEFT BANK

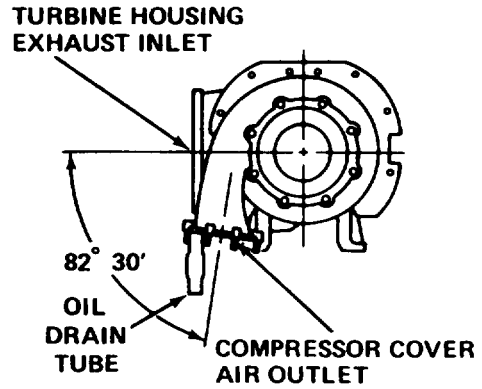

Alignment marks: Compressor cover - A,
Bearing housing - A

RIGHT BANK

Engine model AVDS-1790-2DR.

NOTE: External Shield not used.

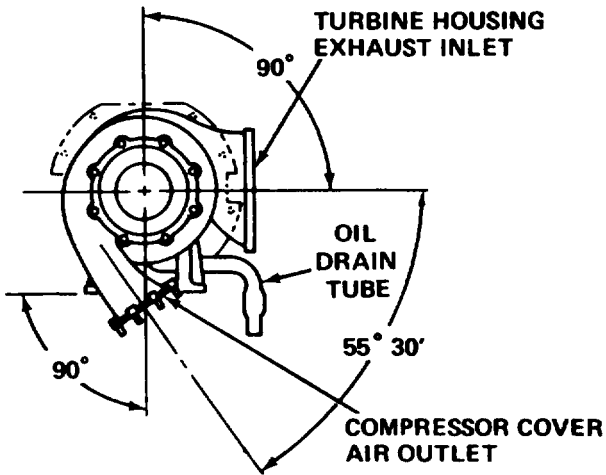

Alignment marks: Compressor cover - C,
Bearing housing - A

LEFT BANK

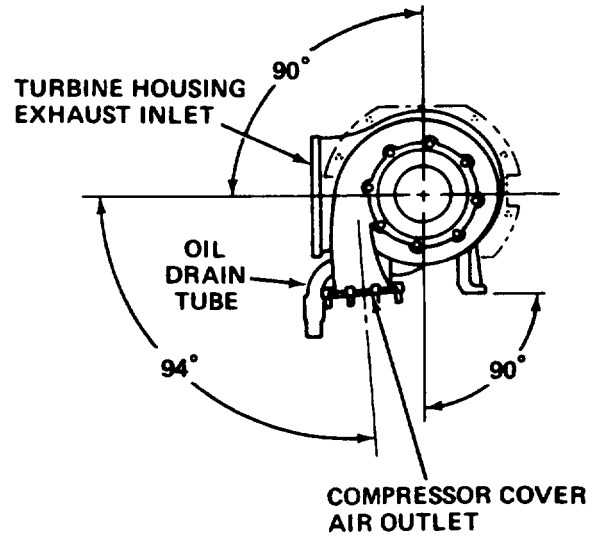

Alignment marks: Compressor cover - B,
Bearing housing - A

RIGHT BANK

ASSEMBLY—Continued.

INSTALL OIL DRAIN TUBE AND MOUNTING LEGS

TOOLS:

- 9/16 inch, 1/2 inch drive socket
- 1/2 inch drive, 5-inch long extension
- 1/2 inch drive, 0 to 300 pound-inches, torque wrench

INSTALLATION :

1. Install gasket (A), oil drain tube (B), and secure with two lockwashers and bolts (C).
2. Using 9/16 inch socket and torque wrench, torque bolts (C) to 275 pound-inches (31 N.m).

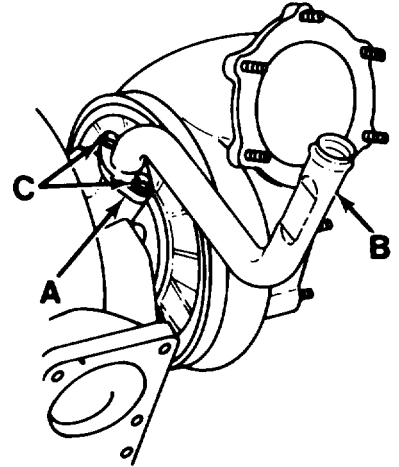

3. Install mounting leg (D) and secure with two lockwashers and bolts (E).
4. Using 9/16 inch socket and torque wrench, torque bolts (E) to 275 pound-inches (31 N.m).

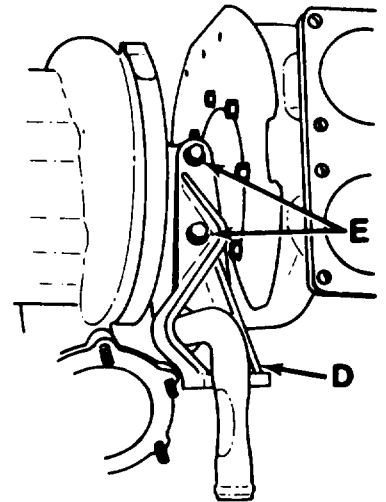

5. Install opposite mounting leg (F) and secure with two lockwashers and bolts (G).
6. Using 9/16 inch socket and torque wrench, torque bolts (G) to 275 pound-inches (31 N.m).

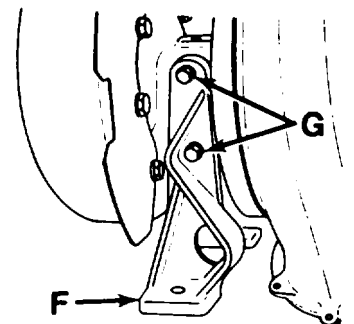

ASSEMBLY—Continued.

7. Install six nuts (A) on turbine housing studs.

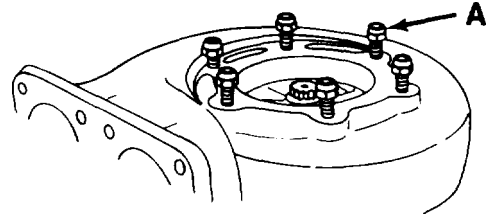

ASSEMBLY—Continued.

INSTALL COMPRESSOR HOUSING INLET AND OUTLET ADAPTERS

TOOLS:

- 9/16 inch, 1/2 inch drive deep well socket
- 5/8 inch, 1/2 inch drive deep well socket
- 1/2 inch drive, 0 to 300 pound-inches torque wrench

NOTE

This procedure applies to "clean air" turbosupercharger only.

INSTALLATION:

1. Install new preformed packings (A) and (B) on compressor housing inlet adapter (C) and outlet adapter (D).

NOTE

The inlet adapter is slightly larger than the outlet adapter and requires the larger preformed packings.

2. Install adapters with preformed packings in compressor housing (E).
3. Using deep well sockets and torque wrench, torque adapters to 60 pound-inches (6.8 N.m).

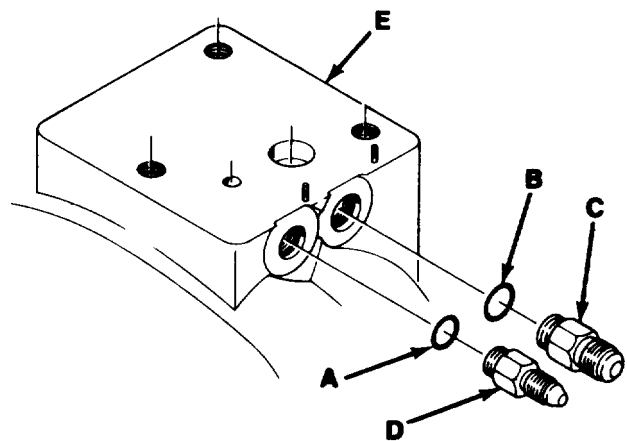

ASSEMBLY-Continued.**INSTALL "O" RINGS, FILTER RETAINING STRAP, AND
FILTER IN DUST DETECTOR COVER**

TOOLS :

None

NOTE

This procedure applies to "clean
air" turbosupercharger only

INSTALLATION:

1. Install three new preformed packings (A) in grooves in underside of dust detector cover (B).
2. Assemble filter retaining strap (C) and filter (D), and install in recess in underside of dust detector cover.

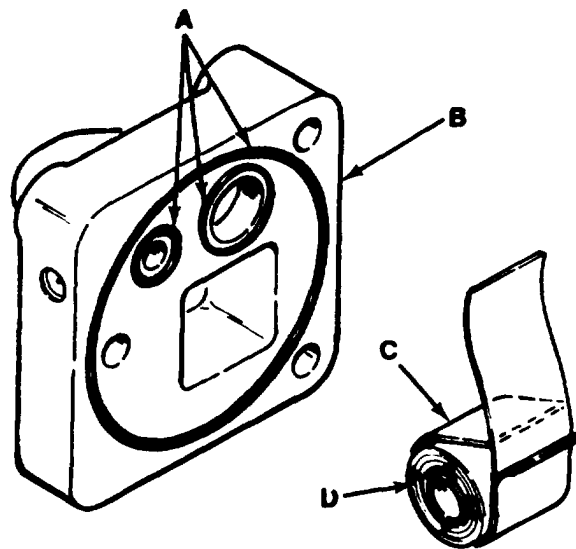

ASSEMBLY—Continued.

INSTALL DUST DETECTOR COVER, PACKING WITH
RETAINER, CHAIN FASTENER, CHAIN "S" HOOK,
AND CHAIN

TOOLS:

- . /2 inch, 1/2 inch drive socket
- 1/2 inch drive, 0 to 300 pound-inches torque wrench

NOTE

This procedure applies to "clean air" turbosupercharger only.

INSTALLATION:

1. Position dust detector cover (A) on compressor housing (B). Ensure mounting holes are properly aligned.
2. Install new packing with retainer (C) on cap screw (D).
3. Install assembled chain fastener (E), "S" hook (F), and chain (G) on cap screw and flat washer (H).
4. Secure dust detector cover to compressor housing with attaching hardware.
5. Using 1/2 inch socket and torque wrench, torque tighten cap screws to 120 pound-inches (13.6 N.m).

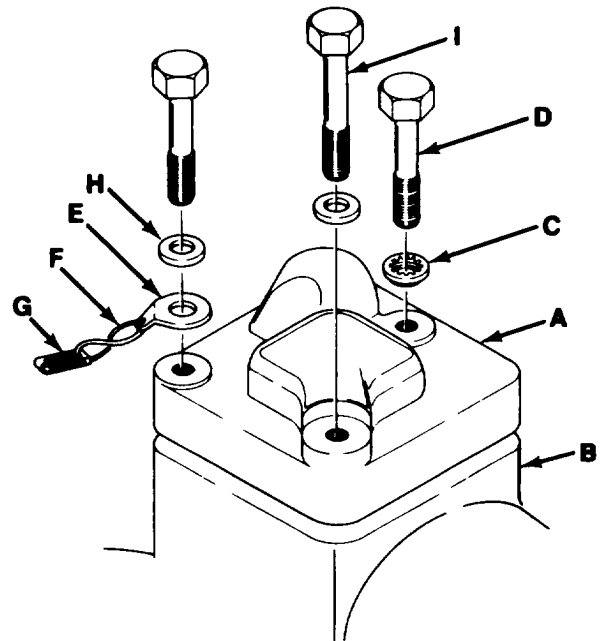

NOTE

Ensure the longer cap screw (I) is installed in the position shown.

CHAPTER 4

TEST AND PRESERVATION

4-1. TEST.

Since turbosupercharger performance depends on engine performance, the turbosupercharger cannot be tested unless it is installed on an engine. Therefore, testing a turbosupercharger not mounted on an engine will consist only of checking the turbine wheel for free rotation and making certain that turbine wheel radial clearance and end play does not exceed dimensions given on page 2-4. If the turbosupercharger passes these tests, it will perform satisfactorily when installed on an engine.

CAUTION

Turbosuperchargers must be lubricated before installation on an engine. Fill the center housing through the oil inlet port with engine oil (OE/HDO 30) before installing the oil inlet hose.

4-2. PRESERVATION.

a. Short Term Storage.

(1) Fill turbosupercharger center housing with Preservative General Purpose Lubrication Oil (VV-L-800). Apply a light coat of the same oil to the exterior surface. Drain excess oil.

(2) Wrap turbosupercharger with Waterproof, Greaseproof Barrier Material (MIL-B-121, Type II, Grade A, Class 2).

(3) Wrap turbosupercharger in Wrapping and Cushioning Paperboard (Federal Specification PPP-P-291, Style I, Type III).

(4) Tape securely with Paper Packing/Masking Tape (Federal Specification PPP-T-42).

(5) Place package in a carton made from Fiberboard Shipping Box Material (Federal Specification PPP-B-636, Style RSC, Type CF, Grade 125, Class DOM).

(6) Tape carton securely with Waterproof Packaging Tape (Federal Specification PPP-T-60).

b. Long Term Storage.

(1) Preserve and package turbosupercharger as outlined above.

(2) Place carton in Interior Packaging Sleeve and Tubing Bag (Federal Specification MIL-B-117, Style I, Type I, Class E). Seal bag using standard heat sealing equipment.

(3) Place sealed bag in a carton made from Fiberboard Shipping Box Material (Federal Specification PPP-B-636, Style RSC, Type CF, Grade 125, weather Resistant).

(4) Tape carton securely with Waterproof Packaging Tape (Federal Specification PPP-T-60).

**APPENDIX A
REFERENCES**

Section 1. GENERAL INFORMATION

A-1 . PURPOSE.

The information contained in this appendix has been prepared as a reference list of those army publications pertinent to the operation and maintenance of the vehicle/weapons systems incorporating the material supported by this publication.

each section of this appendix are arranged in numerical order by publication number.

A-2. ARRANGEMENT OF LISTINGS.

The publications listings contained in

A-3. REQUISITIONING OF PUBLICATIONS.

Copies of the publications referenced, which are required in the performance of your mission, may be requisitioned from Commander, U. S. Army AG Publications Center, 1655 Woodson Road, St. Louis, MO 63144.

Section II. TECHNICAL AND REFERENCE MANUALS

A-4. MAINTENANCE.

- TM 9-247..... Materials used for Cleaning, and Preserving Ordnance Materials.
- TM 9-2815-220-34..... DS and GS Maintenance Manual for Diesel Engines, Models AVDS-1790-2C, 2D, and 2DR.
- TM 38-750..... The Army Maintenance Managenmt System (TAMMS).

A-5. REPAIR PARTS AND SPECIAL TOOLS LISTS (RPSTL).

- TM 9-2815-220-34P..... DS and GS Maintenance Repair Parts and Special Tools Lists for Diesel Engines, Models AVDS-1790-2C, 2D, and 2DR.

A-6. PUBLICATIONS INDEXES.

The following indexes should be consulted frequently for latest changes or re-

visions of references given in this appendix and for new publications relating to material covered in this technical manual.

Index of Army Motion Pictures and Related Audio-Visual Aids DA Pam 108-1

Military Publications:

- Index of Administrative Publications DA Pam 310-1
- Index of Blank Forms DA Pam 310-2
- Index of Doctrinal, Training and Organizational Publications DA Pam 310-3
- Index of Technical Manuals, Technical Bulletins, Supply Manuals (types 7, 8, and 9), supply Bulletins, and Lubrication Orders DA Pam 310-4
- U.S. Army Equipment Index of Modification Work Orders DA Pam 310-7

APPENDIX B

REPAIR PARTS AND SPECIAL TOOLS LIST

Section 1. INTRODUCTION

B-1 . SCOPE.

This appendix lists repair parts and special tools required for the performance of direct and general support maintenance of the AiResearch turbosupercharger. It authorizes the requisitioning and issue of repair parts as indicated by the source and maintenance codes.

<u>Part Number</u>	<u>Engine Application</u>
11669107-1 and 466392-1	AVDS-1790-2A AVDS-1790-2C AVDS-1790-2CA AVDS-1790-2D AVDS-1790-2DA AVDS-1790-2DR

B-2. GENERAL.

This Repair Parts and Special Tools List is divided into the following sections:

a. Section II. Repair Parts List.
A list of repair parts authorized for use in the performance of maintenance. The list also includes parts which must be removed for replacement of the authorized parts. Parts lists are composed of functional groups in numeric sequence, with the parts in each group listed in figure and item number sequence.

b. Section IV. National Stock Number and Part Number Index. A list, in National item identification number (NIIN) (last nine numerals) sequence, of all National stock numbers (NSN) appearing in the listings, folowed by a list in alphanumeric sequence of all part numbers appearing in the listings

National stock numbers and part numbers are cross-referenced to each illustration figure and item number appearance.

B-3. EXPLANATION OF COLUMNS.

a. Illustration. This column is divided as follows:
 (1) Figure Number. Indicates the figure number of the illustration on which the item is shown.
 (2) Item Number. The number used to identify items called out in the illustration.

b. Source, Maintenance, and Recoverability (SMR) Codes.
 (1) Source Code. Source codes indicate the manner of acquiring support items for maintenance, repair, or overhaul of end items. Source codes are entered in the first and second positions of the Uniform SMR code format as follows:

<u>Code</u>	<u>Definition</u>
PA	Item procured and stocked for anticipated or known usage.
PB	Item procured and stocked for insurance purpose because essentiality dictates that a minimum quantity be available in the supply system.
PC	Item procured and stocked and which otherwise would be coded PA except that it is deteriorative in nature.
PD	Support item, excluding support equipment, procured for initial issue or outfitting and stocked only for subsequent or additional initial issues or outfitting. Not subject to automatic replenishment.

TM 9-2990-206-34&P

PE Support equipment procured and stocked for initial issue or outfitting to specified maintenance repair activities.

PF Support equipment which will not be stocked but which will be centrally procured on demand.

PG Item procured and stocked to provide for sustained support for the life of the equipment. It is applied to an item peculiar to the equipment which, because of probable discontinuance or shutdown of production facilities, would prove uneconomical to reproduce at a later time.

KD An item of a depot overhaul/repair kit and not purchased separately. Depot kit defined as a kit that provides items required at the time of overhaul or repair.

KF An item of a maintenance kit and not purchased separately. Maintenance kit defined as a kit that provides an item that can be replaced at organizational or intermediate levels of maintenance.

KB Item included in both a depot overhaul/repair kit and a maintenance kit.

MO Item to be manufactured or fabricated at organizational level.

MF Item to be manufactured or fabricated at the direct support maintenance level.

MH Item to be manufactured or fabricated at the general support maintenance level.

MD Item to be manufactured or fabricated at the depot maintenance level.

AO Item to be assembled at organizational level.

AF Item to be assembled at direct support maintenance level.

AH Item to be assembled at general support maintenance level.

AD Item to be assembled at depot maintenance level.

XA Item is not procured or stocked because the requirements for the item will result in the replacement of the next higher assembly.

XB Item is not procured or stocked. If not available through salvage, requisition.

xc Installation drawing, diagram, instruction sheet, field service drawing, that is identified by manufacturer's part number.

XD A support item that is not stocked. When required, item will be procured through normal supply channels.

NOTE

Cannibalization or salvage may be used as a source of supply for any items coded above except those coded XA.

(2) Maintenance Code. Maintenance codes are assigned to indicate the levels of maintenance authorized to USE and REPAIR support items. The maintenance codes are entered in the third and fourth positions of the Uniform SMR Code format as follows:

(a) The maintenance code entered in the third position will indicate the lowest maintenance level authorized to remove, replace, and use the support item. The maintenance code entered in the third position will indicate one of the following levels of maintenance:

<u>Code</u>	<u>Application/Explanation</u>
C	Crew or operator maintenance performed within organizational maintenance.
0	Support item is removed, replaced, used at the organizational level.

- F Support item is removed, replaced, used at the direct support level.
- H Support item is removed, replaced, used at the general support level.
- D Support items that are removed, replaced, used at depot, mobile depot, or specialized repair activity only.

(b) The maintenance code entered in the fourth position indicates whether the item is to be repaired and identifies the lowest maintenance level with the capability to perform complete repair (i.e., all authorized maintenance functions). This position will contain one of the following maintenance codes.

<u>Code</u>	<u>Appl i cati on/Expl anati on</u>
O	The lowest maintenance level capable of complete repair of the support item is the organizational level.
F	The lowest maintenance level capable of complete repair of the support item is the direct support level.
H	The lowest maintenance level capable of complete repair of the support item is the general support level.
D	The lowest maintenance level capable of complete repair of the support item is the depot level.
L	Repair restricted to (enter applicable designated specialized repair activity), Specialized Repair Activity.
Z	Nonreparable. No repair is authorized.
B	No repair is authorized. The item may be reconditioned by adjusting, lubricating, etc., at the user level. No parts or special tools are procured for the maintenance of this item.

(3) Recoverability Code. Recoverability codes are assigned to support items to indicate the disposition action on unserviceable items. The recoverability code is entered in the fifth position of the Uniform SMR Code format as follows:

<u>Recoverability Codes</u>	<u>Defi ni ti on</u>
Z	Nonreparable item. When unserviceable, condemn and dispose at the level indicated in position 3.
O	Reparable item. When uneconomically repairable, condemn and dispose at organizational level.
F	Reparable item. When uneconomically repairable, condemn and dispose at the direct support level.
H	Reparable item. When uneconomically repairable, condemn and dispose at the general support level.
D	Reparable item. When beyond lower level repair capability, return to depot. Condensation and disposal not authorized below depot level.
L	Reparable item. Repair, condemnation, and disposal not authorized below depot/specialized repair activity level.
A	Item requires special handling or condemnation procedures because of specific reasons (i.e., precious metal content, high dollar value, critical material, or hazardous material). Refer to appropriate manuals/directives for specific instructions.

C. National Stock Number. Indicates the National stock number assigned to the item and which will be used for requisitioning.

d. Part Number. Indicates the primary number used by the manufacturer (Individual, company, firm, corporation, or Government activity), which controls the design and characteristics of the item by means of its engineering drawings, specifications, standards, and inspection requirements to identify an item or range of items.

NOTE

When a stock numbered item is requisitioned, the item received may have a different part number than the part being replaced.

Federal Supply Code for Manufacturer (FSCM). The FSCM is a 5-digit numeric code listed in SB 708-42 which is used to identify the manufacturer, distributor, or Government agency, etc.

f. Description. Indicates the Federal item name and, if required, a minimum description to identify the item. Items that are included in kits and sets are listed below the name of the kit or set with the quantity of each item in the kit or set indicated in the quantity incorporated in unit Column. When the part to be used differs between serial numbers of the same model, the effective serial numbers are shown as the last line of the description. In the Special Tools List, the initial basis of issue (BOI) appears as the last line in the entry for each special tool, special TMDE, and other special support equipment. When density of equipments supported exceeds density spread indicated in the basis of issue, the total authorization is increased accordingly.

g. Unit of Measure (U/M). Indicates the standard of the basic quantity of the listed item as used in performing the actual maintenance function. This measure is expressed by a two-char-

acter alphabetical abbreviation (e.g., ea, in, pr, etc). When the unit of measure differs from the unit of issue, the lowest unit of issue that will satisfy the required units of measure will be requisitioned.

h. Quantity Incorporated in Unit. Indicates the quantity of the item used in the breakout shown on the illustration figure, which is prepared for a functional group, subfunctional group, or an assembly. A "V" appearing in this column in lieu of a quantity indicates that no specific quantity is applicable, (e.g., shims, spacers, etc).

B-4. SPECIAL INFORMATION.

a. Repair Parts Kits. Repair Parts Kits appear as the last entries in the repair parts listing for the figure in which its parts are listed as repair parts.

b. Special Tool Sets. Special tool sets are stocked for initial issue. Tool set components are requisitioned as individual items. Stockage of tools that are duplicated in tool sets for other vehicles assigned or supported are not required beyond actual need.

B-5. HOW TO LOCATE PARTS.

When National Stock number or Part Number Is Unknown:

(1) First. Using the table of contents, determine the functional subgroup within which the item belongs. This is necessary since illustrations are prepared for functional subgroups, and listings are divided into the same groups.

(2) Second. Find the illustration covering the functional subgroup to which the item belongs.

(3) Third. Identify the item on the illustration and note the illustration figure and item number of the item.

(4) Fourth. Using the Repair Parts Listing the figure and item number noted on the illustration.

b. When National Stock Number or Part Number Is Known:

First. Using the index of National Stock Numbers and Part Numbers, find the pertinent National stock

number or part number. This index is in NIIN sequence followed by a list of part numbers in alphameric sequence, cross-referenced to the illustration figure number and item number.

(2) Second After finding the figure and item number, locate the figure and item number in the repair parts list.

Section II. REPAIR PARTS LIST

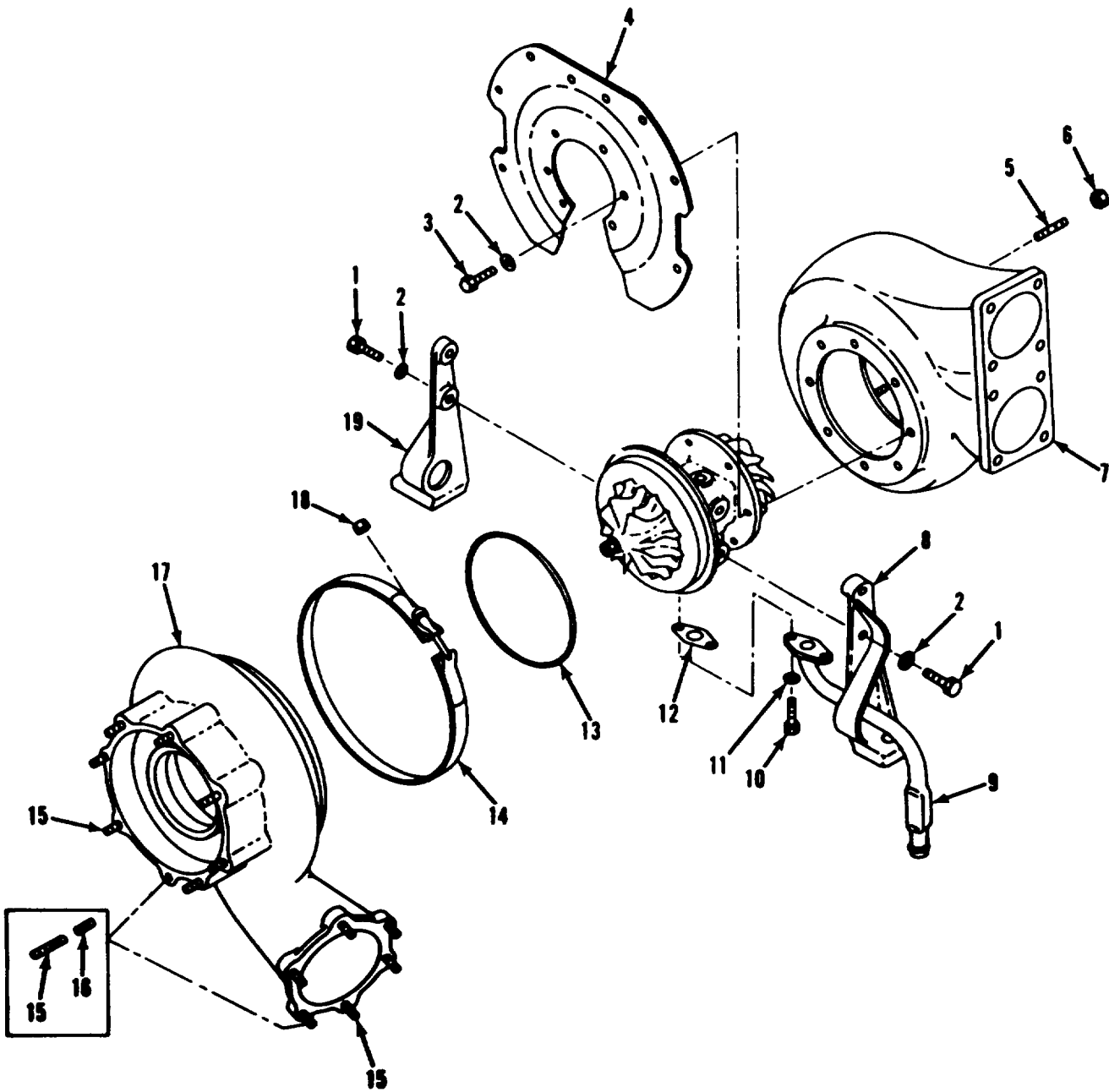

Figure 1. Compressor housing, turbine housing, and associated parts.

TA097834

(1) ILLUSTRATION	(2) FIG. NO.	(3) SMR CODE	(4) NATIONAL STOCK NUMBER	(5) PART NUMBER	(6) FSCM DESCRIPTION	(7) U/M	(8) QTY INC IN UNIT
					GROUP 0305 TURBOSUPERCHARGER, AIRSEARCH MODEL T18C01, PART NUMBER 11669107-1		
1	1	PAHZZ	5306-01-061-1409	S9418822	08179 BOLT, MACHINE: MOUNTING LEGS TO CENTER HOUSING ASSEMBLY	EA	4
1	2	PAHZZ	5310-01-060-7264	400140-400	08179 WASHER, LOCK: MOUNTING LEGS TO CENTER HOUSING ASSEMBLY (4), TURBOSUPERCHARGER SHIELD AND HOUSING ASSEMBLY TO TURBINE HOUSING (8)	EA	12
1	3	PAHZZ	5306-01-061-1408	400132-403	08179 BOLT, MACHINE: TURBOSUPERCHARGER SHIELD AND CENTER HOUSING ASSEMBLY TO TURBINE HOUSING	EA	8
1	4	PAHZZ	2950-01-060-8522	409356	08179 SHIELD, TURBOSUPERCHARGER: HEAT (NOT USED ON ENGINE MODEL AVDS-1790-2DR	EA	1
1	5	PAHZZ	5307-01-059-0120	400602-1	08179 STUD, PLAIN: STANDARD TURBINE HOUSING TO EXHAUST PIPE	EA	6
1	6	PAOZZ	5310-01-151-2732	SPL51712-6	15653 NUT, SELF-LOCKING, HEXAGON: TURBINE HOUSING TO EXHAUST PIPE	EA	6
1	7	XAHZZ		409394-11	08197 HOUSING, TURBINE	EA	1
1	8	XAHZZ		409343	08179 LEG, MOUNTING: RIGHT SIDE	EA	1
1	9	PAFZZ	4710-01-061-0911	409349	08179 TUBE ASSEMBLY, METAL: OIL DRAIN	EA	1
1	10	PAFZZ	5306-01-061-1410	S9418823	08179 BOLT, MACHINE: OIL DRAIN TUBE ASSEMBLY TO CENTER HOUSING ASSEMBLY	EA	2
1	11	PAFZZ	5310-01-060-7264	400140-400	08179 WASHER, LOCK: OIL DRAIN TUBE TO CENTER HOUSING ASSEMBLY	EA	2
1	12	PAFZZ	5330-01-060-6889	409267-2	08179 GASKET: OIL DRAIN TUBE ASSEMBLY, OF KIT PART NO. 409448	EA	1
1	13	KFHZZ		403069-28	08179 PACKING, PREFORMED: COMPRESSOR HOUSING TO BACK PLATE ASSEMBLY, PART OF KIT PART NO. 409448	EA	1
1	14	PFHZZ	5340-01-060-8007	400500-925	08179 COUPLING, CLAMP, GROOVED: COMPRESSOR HOUSING TO BACK PLATE ASSEMBLY	EA	1
1	15	PAHZZ	5307-01-059-0119	400678	08179 STUD, PLAIN: COMPRESSOR HOUSING TO ENGINE AIR INTAKE TUBE (6), COMPRESSOR HOUSING TO VEHICLE AIR INTAKE TUBE (8)	EA	14
1	16	PAHZZ	5340-00-290-4520	MS21208C5-20	96906 INSERT, SCREW THREAD: COMPRESSOR HOUSING STUDS (REPAIR ONLY)	EA	V
1	17	XAHZZ		409373-1	08179 HOUSING, COMPRESSOR	EA	1
1	18	PAHZZ	5310-00-298-2747	MS20500-428	96906 NUT, SELF-LOCKING, HEXAGON: GROOVED CLAMP COUPLING	EA	1
1	19	XAHZZ		409347	08179 LEG, MOUNTING: LEFT SIDE	EA	1

CHANGE 1

B-7

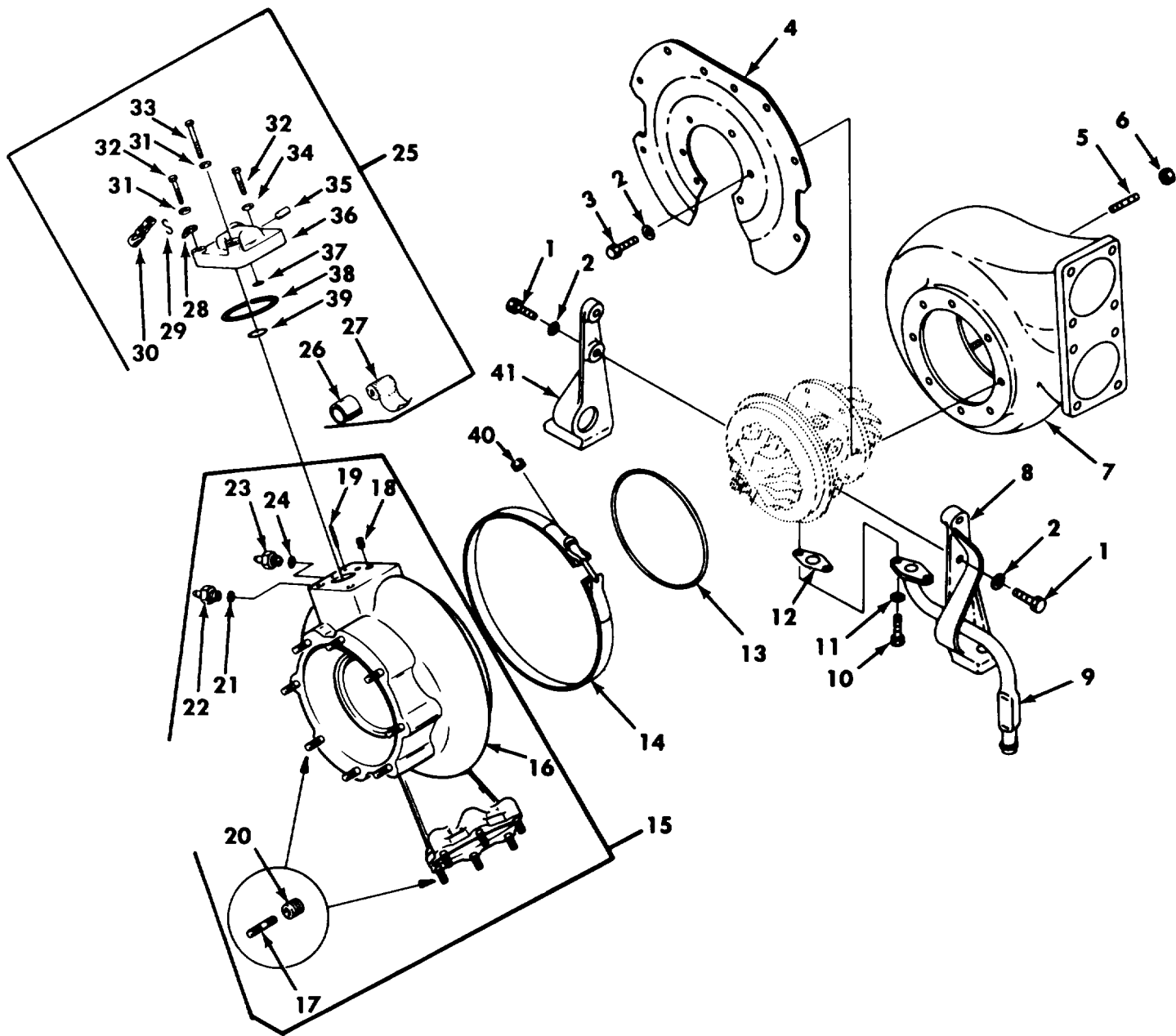

Figure 1.1. Compressor housing, turbine housing, and associated parts.

(1) ILLUSTRATION	(2) FIG. NO.	(3) SMR CODE	(4) NATIONAL STOCK NUMBER	(5) PART NUMBER	(6) FSCM DESCRIPTION	(7) U/M	(8) QTY INC IN UNIT
GROUP 0305							
TURBOSUPERCHARGER, AIRESEARCH MODEL T18C01, PART NUMBER 466392-1							
1.1	1	PAHZZ	5306-01-061-1409	S9418822	08179 BOLT, MACHINE: MOUNTING LEGS TO CENTER HOUSING ASSEMBLY	EA	4
1.1	2	PAHZZ	5310-01-060-7264	400140-400	08179 WASHER, LOCK: MOUNTING LEGS TO CENTER HOUSING ASSEMBLY (4), TURBOSUPERCHARGER SHIELD AND HOUSING ASSEMBLY TO TURBINE HOUSING (8)	EA	12
1.1	3	PAHZZ	5306-01-061-1408	400132-403	08179 BOLT, MACHINE: TURBOSUPERCHARGER SHIELD AND CENTER HOUSING ASSEMBLY TO TURBINE HOUSING	EA	8
1.1	4	PAHZZ	2950-01-060-8522	409356	08179 SHIELD, TURBOSUPERCHARGER: HEAT (NOT USED ON ENGINE MODEL AVDS-1790-2DR)	EA	1
1.1	5	PAHZZ	5307-01-059-0120	400602-1	08179 STUD, PLAIN: STANDARD TURBINE HOUSING TO EJECTOR TUBE	EA	6
1.1	6	PAOZZ	5310-01-151-2732	SPL51712-6	15653 NUT, SELF-LOCKING, HEXAGON: TURBINE HOUSING TO EJECTOR TUBE	EA	6
1.1	7	XAHZZ		409394-11	08197 HOUSING, TURBINE	EA	1
1.1	8	XAHZZ		409343	08179 LEG, MOUNTING: RIGHT SIDE	EA	1
1.1	9	PAFZZ	4710-01-061-0911	409349	08179 TUBE, ASSEMBLY, METAL: OIL DRAIN	EA	1
1.1	10	PAFZZ	5306-01-061-1410	S9418823	08179 BOLT, MACHINE: OIL DRAIN TUBE ASSEMBLY TO CENTER HOUSING ASSEMBLY	EA	2
1.1	11	PAFZZ	5310-01-060-7264	400140-400	08179 WASHER, LOCK: OIL DRAIN TUBE TO CENTER HOUSING ASSEMBLY	EA	2
1.1	12	PAFZZ	5330-01-060-6889	409267-2	08179 GASKET: OIL DRAIN TUBE ASSEMBLY, OF KIT PART NO. 409448	EA	1
1.1	13	KPHZZ		403069-28	08179 PACKING, PREFORMED: COMPRESSOR HOUSING TO BACK PLATE ASSEMBLY, PART OF KIT PART NO. 409448	EA	1
1.1	14	PFHZZ	5340-01-060-8007	400500-925	08179 COUPLING, CLAMP, GROOVED: COMPRESSOR HOUSING TO BACK PLATE ASSEMBLY	EA	1
1.1	15	XAHHH		442153	08179 HOUSING, COMPRESSOR ASSEMBLY	EA	1
1.1	16	XAHZZ		442078-1	08179 HOUSING, COMPRESSOR	EA	1
1.1	17	PFHZZ		400678	08179 STUD, PLAIN: STANDARD, COMPRESSOR COVER TO ENGINE AIR INTAKE TUBE (6), COMPRESSOR COVER TO VEHICLE AIR INTAKE TUBE (8)	EA	14
1.1	18	PAHZZ	5340-00-582-7256	MS21209F5-20	96906 INSERT, SCREW THREAD: DUST DETECTOR COVER SCREW	EA	3
1.1	19	PAHZZ	5315-00-815-3250	MS39086-101	96906 PIN, SPRING:	EA	2
1.1	20	PAHZZ	5340-00-290-4520	MS21208C-20	96906 INSERT, SCREW THREAD: COMPRESSOR COVER-STUD (REPAIR ONLY)	EA	V

CHANGE 1 B-8.1

(1) ILLUSTRATION	(2) ITEM NO.	(3) SMR CODE	(4) NATIONAL STOCK NUMBER	(5) PART NUMBER	(6) FSCM DESCRIPTION	(7) U/M	(8) QTY INC IN UNIT
					TURBOSUPERCHARGER, AIRESEARCH MODEL T18C01, PART NUMBER 466392-1 CONTINUED		
1.1	21	PAOZZ	5330-00-805-2966	MS28778-4	96906 PACKING, PREFORMED: INLET ADAPTER, LOW AIR PRESSURE	EA	1
1.1	22	PAOZZ	4730-01-007-5232	MS51525A4	96906 ADAPTER, STRAIGHT, TUBE TO BOSS: COMPRESSOR COVER INLET	EA	1
1.1	23	PAOZZ	4730-00-431-9307	MS51525A5	96906 ADAPTER, STRAIGHT, TUBE TO BOSS: COMPRESSOR COVER OUTLET	EA	1
1.1	24	PAOZZ	5330-00-833-7491	MS28778-5	96906 PACKING, PREFORMED: OUTLET ADAPTER, HIGH AIR PRESSURE	EA	1
1.1	25	A0000		12275864	19207 COVER ASSEMBLY: DUST DETECTOR	EA	1
1.1	26	PAOZZ	5340-01-145-8291	12275868	19207 STRAP, RETAINING: DUST DETECTOR FILTER	EA	1
1.1	27	PAOZZ	4660-01-145-8299	12275840	19207 FILTER, AIR, ELECTROSTATIC: DUST DETECTOR, POLYESTER CLOTH, 20 MICRON, 10 FT ROLL		
1.1	28	PAOZZ	4030-01-145-8293	12275867	19207 CHAIN FASTENER, ANGLE: DUST DETECTOR COVER TO COMPRESSOR COVER	EA	2
1.1	29	PAOZZ	4030-00-270-5436	MS87006-3	96906 HOOK, CHAIN, S: DUST DETECTOR COVER TO COMPRESSOR COVER	EA	2
1.1	30	MOOZZ		12275841	19207 CHAIN, WELDLESS: DUST DETECTOR COVER TO COMPRESSOR COVER FABRICATE FROM:	EA	V
1.1		PAOZZ		42C16887	21450 CHAIN WELDLESS: 1 PIECE 24 INCHES LONG REQUIRED	FT	1
1.1	31	PAOZZ	5310-00-194-0636	MS9320-11	19207 WASHER, FLAT: DUST DETECTOR COVER TO COMPRESSOR COVER	EA	2
1.1	32	PAOZZ	5305-01-145-8286	12275866-1	19207 SCREW, EXTERNALLY RELIEVED BODY: DUST DETECTOR COVER TO COMPRESSOR COVER	EA	2
1.1	33	PAOZZ	5305-01-145-8287	12275866-2	19207 SCREW, EXTERNALLY RELIEVED BODY: DUST DETECTOR COVER TO COMPRESSOR COVER	EA	1
1.1	34	PAOZZ	5330-00-297-6468	600-01-5-16	83259 PACKING WITH RETAINER: DUST DETECTOR COVER TO COMPRESSOR COVER	EA	1
1.1	35	PAOZZ	4730-00-277-6352	MS27769-1	96906 PLUG, PIPE: DUST DETECTOR COVER	EA	1
1.1	36	PFOZZ	5340-01-145-8310	12275869	19207 COVER, ACCESS: DUST DETECTOR	EA	1
1.1	37	PAOZZ	5330-00-724-7902	MS9068-013	96906 PACKING, PREFORMED: DUST DETECTOR COVER, HIGH AIR PRESSURE OPENING	EA	1
1.1	38	PAOZZ	5330-00-180-9951	MS9068-038	96906 PACKING, PREFORMED, DUST DETECTOR COVER	EA	1
1.1	39	PAOZZ	5330-00-724-5541	MS9068-018	96906 PACKING, PREFORMED: DUST DETECTOR COVER, LOW AIR PRESSURE OPENING	EA	1

CHANGE 1

B-8.2

(1) ILLUSTRATION	(2)	(3)	(4)	(5)	(6)	(7)	(8)
(a) FIG. NO.	(b) ITEM NO. SMR CODE	NATIONAL STOCK NUMBER	PART NUMBER	FSCM	DESCRIPTION	U/M	QTY INC IN UNIT
					GROUP 0305		
					TURBOSUPERCHARGER, AIRESEARCH MODEL T18C01, PART NUMBER 466392-1- CONTINUED		
1.1	40 PAHZZ	5310-00-298-2747	MS20500-428	96906	NUT, SELF-LOCKING, HEXAGON: GROOVED CLAMP COUPLING	EA	1
1.1	41 XAHZZ		409347	08179	LEG, MOUNTING: LEFT SIDE	EA	1

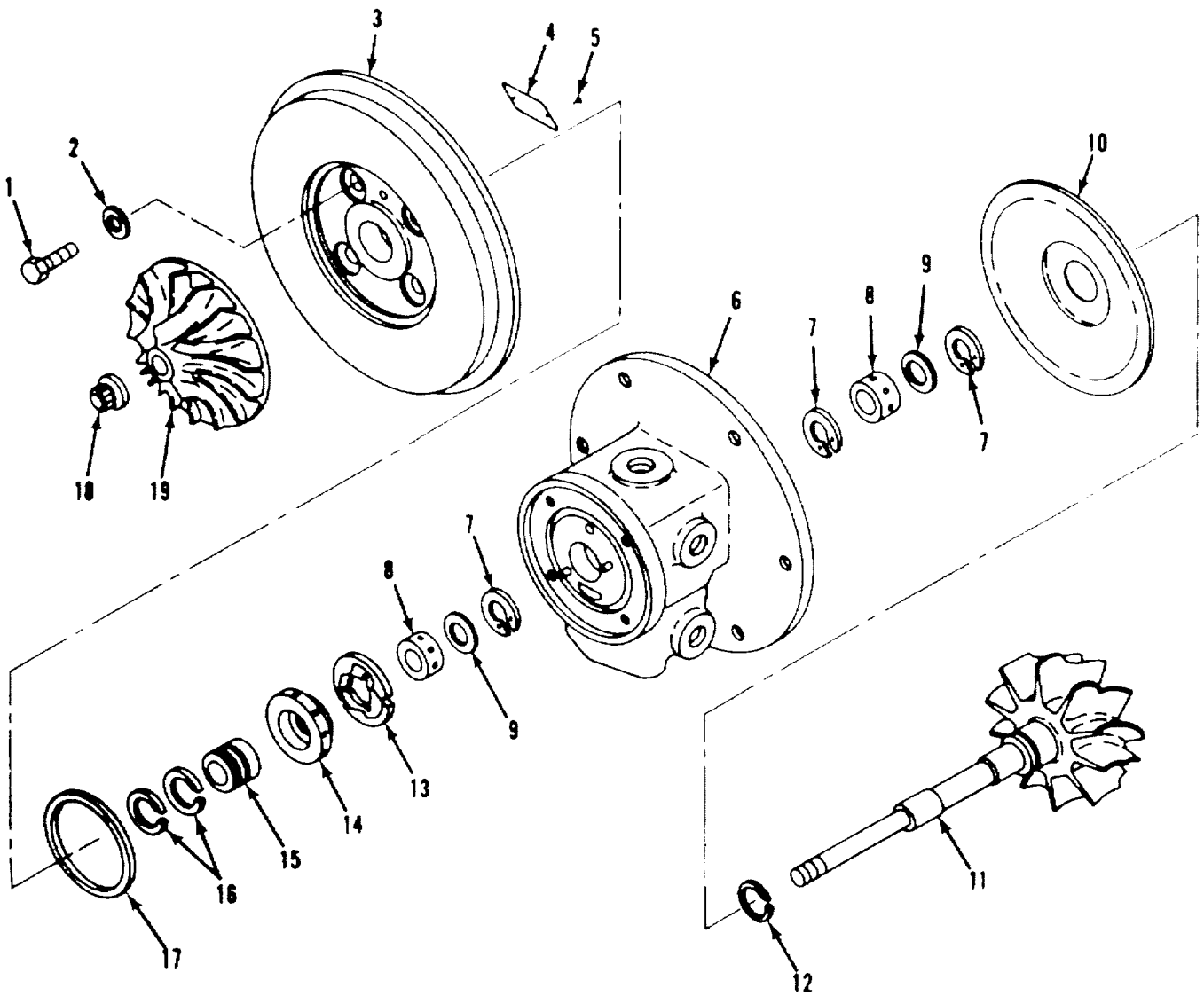

Figure 2. Center housing assembly and associated parts.

(1)	(2)	(3)	(4)	(5)	(6)	(7)	(8)	
ILLUSTRATION								
(a) FIG. NO.	(b) ITEM NO.	SMR CODE	NATIONAL STOCK NUMBER	PART NUMBER	FSCM	DESCRIPTION GROUP 0305 - CONTINUED	U / M	QTY INC IN UNIT
2	1	PAHZZ	5306-01-061-1409	S9418822	08179	BOLT, MACHINE: BACK PLATE ASSEMBLY TO CENTER HOUSING ASSEMBLY	E A	4
2	2	PAHZZ	5310-01-060-9103	400650-2	08179	WASHER, FLAT: BACK PLATE ASSEMBLY TO CENTER HOUSING ASSEMBLY	E A	4
2	3	PAHZZ	2815-01-072-9926	408863-4	08179	BACK PLATE, SUPERCHARGER	E A	1
2	4	XAHZZ		408155	08179	PLATE, IDENTIFICATION: TURBOSUPERCHARGER	E A	1

(1) ILLUSTRATION	(2) FIG. NO.	(3) SMR CODE	(4) NATIONAL STOCK NUMBER	(5) PART NUMBER	(6) FSCM DESCRIPTION	(7) U/M	(8) QTY INC IN UNIT
TM9-2990-206-34&P							
GROUP 03050 - CONTINUED							
2	5	XAHZZ		S173639	08179 SCREW: IDENTIFICATION PLATE	EA	2
2	6	XAHZZ		407214-7	08179 HOUSING ASSEMBLY, CENTER	EA	1
2	7	KFHZZ		400408	08179 RING, RETAINING: THRUST BEARING WASHER AND SLEEVE BEARING, PART OF KIT PART NO. 409448	EA	3
2	8	KFHZZ		408306	08179 BEARING, SLEEVE: TURBINE WHEEL ASSEMBLY, PART OF KIT PART NO. 409448	EA	2
2	9	KFHZZ		407135	08179 WASHER, BEARING, THRUST: TURBINE WHEEL ASSEMBLY, PART OF KIT PART NO. 409448	EA	2
2	10	XAHZZ		407737	08179 WHEEL, SHROUD	EA	1
2	11	PFHZZ	2950-01-059-4219	409352-1	08179 TURBINE WHEEL ASSEMBLY	EA	1
2	12	PAHZZ	2950-00-276-7491	403818-31	70210 SEAL RING , METAL: TURBINE WHEEL ASSEMBLY, PART OF KIT PART NO. 409448	EA	1
2	13	KFHZZ		408844	08179 BEARING, THRUST: TURBINE WHEEL ASSEMBLY, PART OF KIT PART NO. 409448	EA	1
2	14	PFHZZ	2950-00-983-7294	406499-2	08179 RING, THRUST, TURBOCHARGER: TURBINE WHEEL ASSEMBLY	EA	1
2	15	PFHZZ	5365-01-118-8822	408768-1	08179 SPACER, SLEEVE: TURBINE WHEEL ASSEMBLY	EA	1
2	16	PAHZZ	2950-00-821-2077	403818	70210 RING, TURBOCHARGER: THRUST SPACER PART OF KIT PART NO. 409448	EA	2
2	17	KFHZZ		400424-6	08179 SEAL, RING, CENTER HOUSING ASSEMBLY, PART OF KIT PART NO. 409448	EA	1
2	18	PAHZZ	5310-00-070-6870	400379	08179 NUT, SELF-LOCKING, EXTENDED WASHER, DOUBLE HEXAGON: TURBOSUPERCHARGER IMPELLER	EA	1
2	19	PAHZZ	2950-01-060-0962	409269-2	08179 IMPELLER, TURBOSUPERCHARGER	EA	1
2		PAHZZ	2950-01-058-9999	409448	08179 PARTS KIT, TURBOCHARGER	EA	1
COMPOSED OF:							
1	12				GASKET	EA	1
1	13				PACKING, PREFORMED	EA	1
2	7				RING, RETAINING	EA	3
2	8				BEARING, SLEEVE	EA	2
2	9				WASHER, BEARING, THRUST	EA	2
2	12				SEAL, RING, METAL	EA	1
2	13				BEARING, THRUST	EA	1
2	16				RING, TURBOCHARGER	EA	2
2	17				SEAL, RING	EA	1

Section III. SPECIAL TOOLS LIST

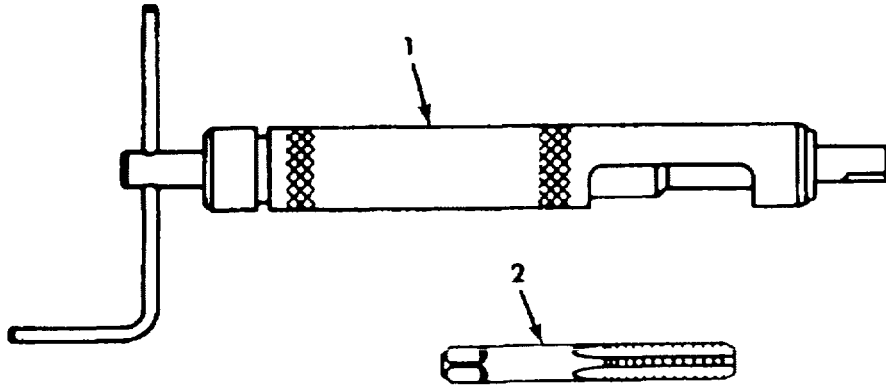

Figure 3. Special tools.

(1)	(2)	(3)	(4)	(5)	(6)	(7)	(8)	
ILLUSTRATION FIG. NO.	ITEM NO.	SMR CODE	NATIONAL STOCK NUMBER	PART NUMBER	FSCM	DESCRIPTION	U/M	QTY INC IN UNIT
3	1	PEHZZ	5120-00-804-6055	3551-5	01556	GROUP 2604 SPECIAL TOOLS INSERTER, SCREW THREAD :5/16-18	EA	1
3	2	PEHZZ		5 C 8 8	26344	TAP, THREAD: 5/16-18 (SPECIAL)	EA	1

National Stock Number Cross Reference to Figure and Item Number

National stock number	National		National stock number	National	
	Fig. no	Item no		Fig. no	Item no
5310-00-070-6870	2	18	5330-01-060-6889	1.1	12
5330-00-180-9951	1.1	38	5310-01-060-7264	1	2
5310-00-194-0636	1.1	31	5310-01-060-7264	1.1	2
4030-00-270-5436	1.1	29	5310-01-060-7264	1	11
2950-00-276-7491	2	12	5310-01-060-7264	1.1	11
4730-00-277-6352	1.1	35	5340-01-060-8007	1	14
5340-00-290-4520	1	16	5340-01-060-8007	1.1	14
5340-00-290-4520	1.1	20	2950-01-060-8522	1	4
5330-00-297-6468	1.1	34	2950-01-060-8522	1.1	4
5310-00-298-2747	1	18	5310-01-060-9103	2	2
5310-00-298-2747	1.1	40	4710-01-061-0911	1	9
4730-00-431-9307	1.1	23	4710-01-061-0911	1.1	9
5340-00-582-7256	1.1	18	5306-01-061-1408	1	3
5330-00-724-5541	1.1	39	5306-01-061-1408	1.1	3
5330-00-724-7902	1.1	37	5306-01-061-1409	1	1
5120-00-804-6055	3	1	5306-01-061-1409	1.1	1
5330-00-805-2966	1.1	21	5306-01-061-1409	2	1
5315-00-815-3250	1.1	19	5306-01-061-1410	1	10
4930-01-145-8293	2	16	5306-01-061-1410	1.1	10
5330-00-833-7491	1.1	24	2815-01-072-9926	2	3
2950-00-983-7294	2	14	5365-01-118-8822	2	15
4730-01-007-5232	1.1	22	5305-01-145-8586	1.1	32
2950-01-058-9999	2	KIT	5305-01-145-8287	1.1	33
5307-01-059-0119	1	15	5340-01-145-8291	1.1	26
5307-01-059-0120	1	5	4060-01-145-8293	1.1	28
5307-01-059-0120	131	5	4460-01-145-8599	1.1	27
2950-01-059-4219	2	11	5340-01-145-8310	1.1	36
2950-01-060-0962	2	19	5310-01-151-2732	1	6
5330-01-060-6889	1	12	5310-01-151-2732	1.1	6

Part Number Cross Reference to Figure and Item Number							
Part number	FSCM	Item		Part number	FSCM	Fig. No.	Item No.
		No.	No.				
MS20500-428	96906	1	18	400500-925	08179	1	14
MS20500-428	96906	1.1	40	400500-925	08179	1.1	14
MS21208C5-20	96906	1	16	400602-1	08179	1	5
MS21208C5-20	96906	1.1	20	400602-1	08179	1.1	5
MS21209F5-20	96906	1.1	18	400650-2	08179	2	2
MS27769-1	96906	1.1	35	400678	08179	1	15
MS28778-4	96906	1.1	21	400678	08179	1.1	17
MS28778-5	96906	1.1	24	403069-28	08179	1	13
MS39086-101	96906	1.1	19	403069-28	08179	1.1	13
MS50525A4	96906	1.1	22	403818	70210	2	16
MS51525A5	96906	1.1	23	403818-31	70210	2	12
MS87006-3	96906	1.1	28	406499-2	08179	2	14
MS9068-013	96906	1.1	37	407135	08179	2	9
MS9068-018	96906	1.1	39	407214-7	08179	2	6
MS9068-038	96906	1.1	38	407737	08179	2	10
MS9320-11	19207	1.1	30	408155	08179	2	4
S173639	08179	2	5	408306	08179	2	8
S9418822	08179	1	1	408768-1	08179	2	15
S9418822	08179	1.1	1	408844	08179	2	13
S9418822	08179	2	1	408863-4	08179	2	3
S9418823	08179	1	10	409267-2	08179	1	12
S9418823	08179	1.1	10	409267-2	08179	1.1	12
SPL51712-6	15653	1	6	409269-2	08179	2	19
SPL51712-6	15653	1.1	6	409343	08179	1	8
12275840	19207	1.1	26	409343	08179	1.1	8
12275841	19207	1.1	29	409347	08179	1	19
12275864	19207	1.1	34	409347	08179	1.1	41
12275866-1	19207	1.1	31	409349	08179	1	9
12275866-2	19207	1.1	32	409349	08179	1.1	9
12275867	19207	1.1	27	49352-1	08179	2	11
12275868	19207	1.1	25	409356	08179	1	4
12275869	19207	1.1	36	409356	08179	1.1	4
3551-5	01556	3	1	409373-1	08179	1	17
400132-403	08179	1	3	409397-11	08179	1	7
400132-403	08179	1.1	3	409394-11	08179	1.1	7
400140-400	08179	1	2	409448	08179	2	KIT
400140-400	08179	1.1	2	42C16887	21450	1.1	
400140-400	08179	1	11	442078-1	08179	1.1	16
400140-400	08179	1.1	11	442153	08179	1.1	15
400379	08179	2	18	5CBB	26344	3	2
400408	08179	2	7	600-01-5-16	83259	1.1	34
400424-6	08179	2	17				

APPENDIX C

EXPENDABLE SUPPLIES AND MATERIALS LIST

This appendix lists expendable supplies and material you will need to

repair the AiResearch Model T18C01 turbosupercharger.

Item	NSN	Description	Unit of measure
1.	7920-00-205-1711	RAG, WIPING, COTTON, WHITE: 50 lb bale, DDD-R-30 (81348)	lb
2.	9150-00-231-6689	PL SPECIAL LUBE OIL: 1 qt can, VV-L-800 (81348)	qt
3.	6850-00-281-1985	SD DRYCLEANING SOLVENT: 1 gal - lon can, P-D-WI, Type II	gal
4.	9150-00-948-6912	SOLID FILM LUBRICANT, HEAT- CURED, CORROSION INHIBITING: MIL-L-46010	qt
	9150-00-948-7025	SOLID FILM LUBRICANT, HEAT- CURED, CORROSION INHIBITING: MIL-L-46010	gal

ALPHABETICAL INDEX

Subject, Page Number

A

Alphabetical Index, Index
 Appendix A, A-1
 Appendix B, B-1
 Appendix C, C-1

B

Backplate
 Inspection, 3-12
 Installation, 3-22
 Removal, 3-7
 Repair, 3-16

C

Center Housing Assembly
 Inspection, 3-14
 Installation, 3-24, 3-25
 Removal, 3-4
 Repair, 3-17

Chain
 Installation, 3-30
 Removal, 3-10

Chain Fastener
 Installation, 3-30
 Removal, 3-10

Chain "S" Hook
 Installation, 3-30
 Removal, 3-10

Clamp (See Grooved Clamp Coupling)

Cleaning, 3-10

Common Tools, 3-1

Common Tools and Equipment, 2-5

Compressor Housing
 Inspection, 3-10
 Installation, 3-25
 Removal, 3-3
 Repair, 3-16

Compressor Wheel (See Turbosupercharger Impeller)

Compressor Wheel Nut (See Impeller Nut)

D

Description of Turbosupercharger, 1-2

Dust Detector Cover
 Inspection, 3-16
 Installation, 3-30
 Removal, 3-10

E

End Play, 2-4

Expendable Materials, 3-1

Expendable Supplies and Materials List,

F

Filter
 Installation, 3-29
 Removal, 3-10.1

Filter Retaining Strap
 Installation, 3-29
 Removal, 3-10.1

G

Grooved Clamp Coupling
 Inspection,
 Installation
 Removal, 3-3
 Repair, 3-17

H

Heat Shield (See Turbosupercharger Shield)

Holding Fixture, 2-5, 3-5, 3-23

How to Locate Parts, B-4

How to Use This Manual, iii

I

Identification of Models, 1-1
 Impeller Nut
 Inspection, 3-12
 Installation, 3-22
 Removal, 3-5
 Improvised Tools, 2-5
 Index Positions, 3-23, 3-24
 Insert (See Screw Thread Insert)
 Inspection, 3-10

L

Long Term Storage, 4-1
 Lubrication, 1-2

M

Maintenance Forms, Record, and Reports, 1-1
 Maintenance Instructions, 2-1
 Inspection, 2-1
 Troubleshooting, 2-2
 Metal Ring Seal
 Installation, 3-20
 Removal, 3-7
 Metal Tube Assembly
 Inspection, 3-11
 Installation, 2-4, 3-26
 Removal, 2-3, 3-2,
 Repair, 3-16
 Mounting Legs
 Inspection, 3-11
 Installation, 3-26
 Removal, 3-2
 Repair, 3-16

N

National Stock Number and Part Number Index, 6-11
 Nomenclature Cross-reference List, 1-1

O

Oil Drain Tube (See Metal Tube Assembly)
 Operation of Turbosupercharger, 1-2
 "O" Ring (See Preformed Packing)
 "O" Ring (See Ring Seal)

P

Packing with Retainer
 Installation, 3-30
 Removal, 3-10
 Part Number Variations of Basic Model., 1-3
 Plain Stud
 Inspection, 3-10, 3-11
 Installation, 3-16, 3-17
 Removal, 3-16, 3-17
 Preformed Packing
 Installation, 3-21, 3-25, 3-29
 Removal, 3-3, 3-8, 3-10.1
 Preservation, 4-1
 Publication Indexes, A-2
 Purpose of Equipment, 1-1

R

Radial Clearance, 2-3
 Repair of Turbosupercharger, 3-16
 Repair Equipment, 3-1
 Repair Parts, 2-5, 3-1
 Repair Parts and Special Tools List, B-1
 Repair Parts List, B-6
 Reporting Equipment Improvement Recommendations (EIR), 1-2
 Requisitioning of Publications, A-1
 Retaining Ring
 Installation, 3-18, 3-19
 Removal, 3-9
 Ring Seal
 Installation, 3-20, 3-21
 Removal, 3-7, 3-8

S

Screw Thread Insert
 Installation, 3-16
 Seal Ring (See Metal Ring Seal)
 Shop Equipment, 3-1
 Short Term Storage, 4-1
 Shroud (See Shroud Wheel)
 Shroud Wheel
 Inspection, 3-15
 Installation, 3-20
 Removal, 3-6
 Repair, 3-16

Sleeve Bearing, 1-2
 Installation, 3-19
 Removal, 3-8, 3-9
 Spacer Ring (See Turbosupercharger Ring)
 Special Information, B-4
 Special Tool, 2-5
 Special Tools List, B-10
 Specifications, 1-4
 Stud (See Plain Stud)

T

Technical and Reference Manuals, A-1
 Test, 4-1
 Thread Tap, 2-5
 Thrust Bearing
 Installation, 3-20
 Removal, 3-8
 Thrust Bearing Washer
 Installation, 3-19
 Removal, 3-8, 3-9
 Thrust Ring (See Turbosupercharger Thrust Ring)
 Thrust Spacer
 Inspection, 3-13
 Installation, 3-21
 Removal, 3-7
 Thrust Washer (See Thrust Bearing Washer)

Troubleshooting, 2-1
 Turbine Housing
 Inspection, 3-11
 Installation, 3-24, 3-25
 Removal, 3-4
 Repair, 3-17
 Turbine Wheel (See Turbine Wheel Assembly)
 Turbine Wheel Assembly
 Inspection, 3-15
 Installation, 3-20
 Removal, 3-6
 Turbosupercharger Ring
 Installation, 3-21
 Removal, 3-7
 Turbosupercharger Thrust Ring
 Inspection, 3-13
 Installation, 3-21
 Removal, 3-8
 Turbosupercharger Impeller
 Inspection, 3-12
 Installation, 3-22
 Removal, 3-6
 Turbosupercharger Shield
 Inspection, 3-11
 Installation, 3-24
 Removal, 3-4
 Repair, 3-16

BY Order of the Secretary of the Army:

E. C. MEYER
General, United States Army
Chief of Staff

Official:

J. C. PENNINGTON
Major General, United States Army
The Adjutant General

DISTRIBUTION:

To be distributed in accordance with DA Form 12-37, Direct and General Support Maintenance requirements for Medium, M88A1; Tank, Combat, Full Tracked; 105MM Gun, M60A1 (RISE); Tank, Combat Full Tracked: 105MM Gun, M48A5, and M60A3 Tank Turret.



SOMETHING WRONG WITH THIS MANUAL?

THEN... JOT DOWN THE DOPE ABOUT IT ON THIS FORM. TEAR IT OUT, FOLD IT AND DROP IT IN THE MAIL!

FROM: (YOUR UNIT'S COMPLETE ADDRESS)

Your mailing address.

DATE Date you fill out this form.

PUBLICATION NUMBER

TM 9-XXXX-XXX-XX

DATE

Date of TM

TITLE

Title of TM

BE EXACT... PIN-POINT WHERE IT IS

IN THIS SPACE TELL WHAT IS WRONG AND WHAT SHOULD BE DONE ABOUT IT:

PAGE NO.	PARA-GRAPH	FIGURE NO.	TABLE NO.
3		2	
109		51	
2-8			2-1
12	1-6a		

Item 10. Change illustration. Reason: Tube end shown assembled on wrong side of lever cam.

Item 3. The NSN and P/N are not listed on the AMDF nor the MCRL. Request correct NSN and P/N be furnished.

Preventive Maintenance Checks and Services. Item 7 under "Items to be inspected" should be changed to read as follows: Firing linkage and firing mechanism pawl.

Since there are both 20- and 30- round magazines for this rifle, data on both should be listed.

SAMPLE

TEAR ALONG DOTTED LINE

TYPED NAME, GRADE OR TITLE, AND TELEPHONE NUMBER

SIGN HERE:

RECOMMENDED CHANGES TO EQUIPMENT TECHNICAL MANUALS



SOMETHING WRONG WITH THIS MANUAL?

THEN... JOT DOWN THE DOPE ABOUT IT ON THIS FORM, TEAR IT OUT, FOLD IT AND DROP IT IN THE MAIL!

FROM: (YOUR UNIT'S COMPLETE ADDRESS)

DATE

PUBLICATION NUMBER

TM 9-2990-206-34&P

DATE

TITLE DS and GS Maintenance Manual, Including RPSTL, For AiResearch Turbosupercharger, Model T18C01

BE EXACT... PIN-POINT WHERE IT IS

IN THIS SPACE TELL WHAT IS WRONG AND WHAT SHOULD BE DONE ABOUT IT:

PAGE NO.

PARA-GRAPH

FIGURE NO.

TABLE NO.

TEAR ALONG DOTTED LINE

TYPED NAME, GRADE OR TITLE, AND TELEPHONE NUMBER

SIGN HERE:

COMMANDER
US ARMY TANK-AUTOMOTIVE MATERIEL READINESS COMMAND
WARREN, MICHIGAN 48090
ATTN: DRSTA-MB

FOLD

FOLD

TEAR OUT ALONG PERFORATIONS

THE METRIC SYSTEM AND EQUIVALENTS

LINEAR MEASURE

1 Centimeter = 10 Millimeters = 0.01 Meters = 0.3937 Inches
 1 Meter = 100 Centimeters = 1000 Millimeters = 39.37 Inches
 1 Kilometer = 1000 Meters = 0.621 Miles

WEIGHTS

1 Gram = 0.001 Kilograms = 1000 Milligrams = 0.035 Ounces
 1 Kilogram = 1000 Grams = 2.2 Lb
 1 Metric Ton = 1000 Kilograms = 1 Megagram = 1.1 Short Tons

LIQUID MEASURE

1 Milliliter = 0.001 Liters = 0.0338 Fluid Ounces
 1 Liter = 1000 Milliliters = 33.82 Fluid Ounces

SQUARE MEASURE

1 Sq Centimeter = 100 Sq Millimeters = 0.155 Sq Inches
 1 Sq Meter = 10,000 Sq Centimeters = 10.76 Sq Feet
 1 Sq Kilometer = 1,000,000 Sq Meters = 0.386 Sq Miles

CUBIC MEASURE

1 Cu Centimeter = 1000 Cu Millimeters = 0.06 Cu Inches
 1 Cu Meter = 1,000,000 Cu Centimeters = 35.31 Cu Feet

TEMPERATURE

$5/9 (^{\circ}\text{F} - 32) = ^{\circ}\text{C}$
 212^o Fahrenheit is equivalent to 100^o Celsius
 90^o Fahrenheit is equivalent to 32.2^o Celsius
 32^o Fahrenheit is equivalent to 0^o Celsius
 $9/5 \text{ C}^{\circ} + 32 = \text{F}^{\circ}$

APPROXIMATE CONVERSION FACTORS

<u>TO CHANGE</u>	<u>TO</u>	<u>MULTIPLY BY</u>
Inches	Centimeters	2.540
Feet	Meters	0.305
Yards	Meters	0.914
Miles	Kilometers	1.609
Square Inches	Square Centimeters	6.451
Square Feet	Square Meters	0.093
Square Yards	Square Meters	0.836
Square Miles	Square Kilometers	2.590
Acres	Square Hectometers	0.405
Cubic Feet	Cubic Meters	0.028
Cubic Yards	Cubic Meters	0.765
Fluid Ounces	Milliliters	29.573
Pints	Liters	0.473
Quarts	Liters	0.946
Gallons	Liters	3.785
Ounces	Grams	28.349
Pounds	Kilograms	0.454
Short Tons	Metric Tons	0.907
Pound-Feet	Newton-Meters	1.356
Pounds per Square Inch	Kilopascals	6.895
Miles per Gallon	Kilometers per Liter	0.425
Miles per Hour	Kilometers per Hour	1.609

<u>TO CHANGE</u>	<u>TO</u>	<u>MULTIPLY BY</u>
Centimeters	Inches	0.394
Meters	Feet	3.280
Meters	Yards	1.094
Kilometers	Miles	0.621
Square Centimeters	Square Inches	0.155
Square Meters	Square Feet	10.764
Square Meters	Square Yards	1.196
Square Kilometers	Square Miles	0.386
Square Hectometers	Acres	2.471
Cubic Meters	Cubic Feet	35.315
Cubic Meters	Cubic Yards	1.308
Milliliters	Fluid Ounces	0.034
Liters	Pints	2.113
Liters	Quarts	1.057
Liters	Gallons	0.264
Grams	Ounces	0.035
Kilograms	Pounds	2.205
Metric Tons	Short Tons	1.102
Newton-Meters	Pound-Feet	0.738
Kilopascals	Pounds per Square Inch	0.145
Kilometers per Liter	Miles per Gallon	2.354
Kilometers per Hour	Miles per Hour	0.621

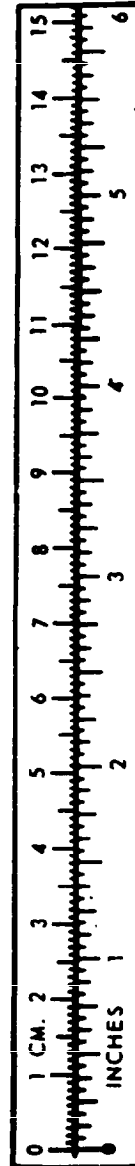

TA089991

